

27 November 2012

Agreement

Concerning the Adoption of Uniform Technical Prescriptions for Wheeled Vehicles, Equipment and Parts which can be fitted and/or be used on Wheeled Vehicles and the Conditions for Reciprocal Recognition of Approvals Granted on the Basis of these Prescriptions*

(Revision 2, including the amendments, which entered into force on 16 October 1995)

Addendum 13: Regulation No. 14

Revision 5

Incorporating all valid text up to:

Corrigendum 4 to the 06 series of amendments - Date of entry into force: 15 November 2006

Supplement 3 to the 06 series of amendments - Date of entry into force: 11 June 2007

Supplement 4 to the 06 series of amendments - Date of entry into force: 26 February 2009

Supplement 5 to the 06 series of amendments - Date of entry into force: 22 July 2009

07 series of amendments - Date of entry into force: 22 July 2009

Supplement 1 to the 07 series of amendments - Date of entry into force: 19 August 2010

Corrigendum 1 to the Revision 04 - Date of entry into force: 22 June 2011

Supplement 2 to the 07 series of amendments - Date of entry into force: 13 April 2012

Supplement 3 to the 07 series of amendments - Date of entry into force: 26 July 2012

Uniform provisions concerning the approval of vehicles with regard to safety-belt anchorages, ISOFIX anchorages systems and ISOFIX top tether anchorages



UNITED NATIONS

* Former title of the Agreement: Agreement Concerning the Adoption of Uniform Conditions of Approval and Reciprocal Recognition of Approval for Motor Vehicle Equipment and Parts, done at Geneva on 20 March 1958.

Regulation No. 14

Uniform provisions concerning the approval of vehicles with regard to safety-belt anchorages, ISOFIX anchorages systems and ISOFIX top tether anchorages

Contents

| | <i>Page</i> |
|---|-------------|
| 1. Scope | 4 |
| 2. Definitions | 4 |
| 3. Application for approval | 8 |
| 4. Approval | 9 |
| 5. Specifications | 10 |
| 6. Tests | 21 |
| 7. Inspection during and after static tests for safety-belt anchorages | 29 |
| 8. Modifications and extension of approval of the vehicle type | 29 |
| 9. Conformity of production | 30 |
| 10. Penalties for non-conformity of production | 30 |
| 11. Operating instructions | 30 |
| 12. Production definitively discontinued | 31 |
| 13. Names and addresses of Technical Services responsible for conducting approval tests, and of Type Approval Authorities | 31 |
| 14. Transitional provisions | 31 |
| Annexes | |
| 1. Communication | 34 |
| 2. Arrangements of the approval mark | 36 |
| 3. Location of effective belt anchorages | 37 |
| 4. Procedure for determining the "H" point and the actual torso angle for seating positions in motor vehicles..... | 39 |
| Appendix 1 - Description of the three-dimensional "H" point machine | 39 |
| Appendix 2 - Three-dimensional reference system | 39 |
| Appendix 3 - Reference data concerning seating positions | 39 |
| 5. Traction device | 40 |
| 6. Minimum number of anchorage points and location of lower anchorages..... | 44 |
| Appendix 1 - Location of lower anchorages – Angle requirements only | 45 |
| 7. Dynamic test as an alternative to the safety-belt anchorages static strength test..... | 46 |
| 8. Dummy specifications..... | 48 |
| 9. ISOFIX anchorages systems and ISOFIX top tether anchorages | 49 |
| | 3 |

1. Scope

This Regulation applies to:

- (a) Vehicles of categories M and N¹ with regard to their anchorages for safety-belts intended for adult occupants of forward-facing or rearward-facing or side-facing seats;
- (b) Vehicles of category M₁ with regard to their ISOFIX anchorage systems and their ISOFIX top tether anchorages intended for child restraint systems. Other categories of vehicles fitted with ISOFIX anchorages have also to comply with the provisions of this Regulation.
- (c) Vehicles of any category with regard to their i-Size seating positions, if any are defined by the vehicle manufacturer."

2. Definitions

For the purposes of this Regulation,

- 2.1. "*Approval of a vehicle*" means the approval of a vehicle type equipped with anchorages for given types of safety-belts;
- 2.2. "*Vehicle type*" means a category of power-driven vehicles, which do not differ in such essential respects as the dimensions, lines and materials of components of the vehicle structure or seat structure to which the safety-belts anchorages and the ISOFIX anchorages systems and ISOFIX top tether anchorages if any are attached and, if the anchorages strength is tested according to the dynamic test, the characteristics of any component of the restraint system, especially the load limiter function, having an influence on the forces applying to the safety-belt anchorages. if the anchorages strength is tested according to the dynamic test, as well as the vehicle floor strength when tested according to the static test in case of i-Size seating positions, the characteristics of any component of the restraint system, especially the load limiter function, having an influence on the forces applying to the safety-belt anchorages."
- 2.3. "*Belt anchorages*" means the parts of the vehicle structure or the seat structure or any other part of the vehicle to which the safety-belt assemblies are to be secured;
- 2.4. "*Effective belt anchorage*" means the point used to determine conventionally, as specified in paragraph 5.4., the angle of each part of the safety-belt in relation to the wearer, that is, the point to which a strap would need to be attached to provide the same lie as the intended lie of the belt when worn, and which may or may not

¹ As defined in the Consolidated resolution on the Construction of vehicles (R.E.3), document ECE/TRANS/WP.29/78/Rev.2, para.2.

be the actual belt anchorage depending on the configuration of the safety-belt hardware at its attachment to the belt anchorage.

- 2.4.1. For example, in the case
 - 2.4.1.1. Where a strap guide is used on the vehicle structure or on the seat structure, the middle point of the guide at the place where the strap leaves the guide on the belt wearer's side, shall be considered as the effective belt anchorage; and,
 - 2.4.1.2. where the belt runs directly from the wearer to a retractor attached to the vehicle structure or the seat structure without an intervening strap guide, the effective belt anchorage shall be considered as being the intersection of the axis of the reel for storing the strap with the plane passing through the centre line of the strap on the reel;
- 2.5. "*Floor*" means the lower part of the vehicle body-work connecting the vehicle side walls. In this context it includes ribs, swages and possibly other reinforcements, even if they are below the floor, such as longitudinal and transverse members;
- 2.6. "*Seat*" means a structure which may or may not be integral with the vehicle structure complete with trim, intended to seat one adult person. The term covers both an individual seat or part of a bench seat intended to seat one person;
 - 2.6.1. "*Front passenger seat*" means any seat where the "foremost H point" of the seat in question is in or in front of the vertical transverse plane through the driver's R point;
 - 2.6.2. "*Forward-facing seat*" means a seat which can be used while the vehicle is in motion and which faces towards the front of the vehicle in such a manner that the vertical plane of symmetry of the seat forms an angle of less than +10° or -10° with the vertical plane of symmetry of the vehicle.
 - 2.6.3. "*Rearward-facing seat*" means a seat which can be used while the vehicle is in motion and which faces towards the rear of the vehicle in such a manner that the vertical plane of symmetry of the seat forms an angle of less than +10° or -10° with the vertical plane of symmetry of the vehicle.
 - 2.6.4. "*Side-facing seat*" means a seat which can be used while the vehicle is in motion and which faces towards the side of the vehicle in such a manner that the vertical plane of symmetry of the seat forms an angle of 90° (±10°) with the vertical plane of symmetry of the vehicle.
- 2.7. "*Group of seats*" means either a bench-type seat, or seats which are separate but side by side (i.e. with the foremost anchorages of one seat in line with or forward of the rearmost anchorages and in line with or behind the foremost anchorages of another seat) and accommodate one or more seated adult person;
- 2.8. "*Bench seat*" means a structure complete with trim, intended to seat more than one adult person;
- 2.9. "*Seat type*" means a category of seats which do not differ in such essential respects as:
 - 2.9.1. The shape, dimensions and materials of the seat structure,
 - 2.9.2. The types and dimensions of the adjustment systems and all locking systems,

- 2.9.3. The type and dimensions of the belt anchorages on the seat, of the seat anchorage and of the affected parts of the vehicle structure;
- 2.10. "*Seat anchorage*" means the system by which the seat assembly is secured to the vehicle structure, including the affected parts of the vehicle structure;
- 2.11. "*Adjustment system*" means the device by which the seat or its parts can be adjusted to a position suited to the morphology of the seated occupant; this device may, in particular, permit of:
- 2.11.1. Longitudinal displacement;
- 2.11.2. Vertical displacement;
- 2.11.3. Angular displacement;
- 2.12. "*Displacement system*" means a device enabling the seat or one of its parts to be displaced or rotated without a fixed intermediate position, to permit easy access to the space behind the seat concerned;
- 2.13. "*Locking system*" means any device ensuring that the seat and its parts are maintained in any position of use and includes devices to lock both the seat back relative to the seat and the seat relative to the vehicle.
- 2.14. "*Reference zone*" means the space between two vertical longitudinal planes, 400 mm apart and symmetrical with respect to the H point, and defined by rotation from vertical to horizontal of the head form apparatus, as described in Regulation No. 21, Annex 1. The apparatus shall be positioned as described in that Annex to Regulation No. 21 and set to the maximum length of 840 mm.
- 2.15. "*Thorax load limiter function*" means any part of the safety-belt and/or the seat and/or the vehicle intended to limit the level of the restraint forces applying to the occupant thorax in case of a collision.
- 2.16. "*ISOFIX*" is a system for the connection of child restraint systems to vehicles which has two vehicle rigid anchorages, two corresponding rigid attachments on the child restraint system and a mean to limit the pitch rotation of the child restraint system.
- 2.17. "*ISOFIX position*" means a position which allows the installation of:
- (a) Either an universal ISOFIX forward facing child restraint system as defined in Regulation No. 44;
 - (b) Or a semi-universal ISOFIX forward facing child restraint system as defined in Regulation No. 44,
 - (c) Or a semi-universal ISOFIX rearward facing child restraint system as defined in Regulation No. 44,
 - (d) Or a semi-universal ISOFIX lateral facing position child restraint system as defined in Regulation No. 44,
 - (e) Or a specific vehicle ISOFIX child restraint system as defined in Regulation No. 44.
 - (f) Or an i-Size child restraint system as defined in Regulation No. 129,
 - (g) Or a specific vehicle ISOFIX child restraint system as defined in Regulation No. 129."

- 2.18. "*ISOFIX low anchorage*" means one 6 mm diameter rigid round horizontal bar, extending from vehicle or seat structure to accept and restrain an ISOFIX child restraint system with ISOFIX attachments.
- 2.19. "*ISOFIX anchorages system*" means a system made up of two ISOFIX low anchorages which is designed for attaching an ISOFIX child restraint system in conjunction with an anti-rotation device.
- 2.20. "*ISOFIX ATTACHMENT*" means one of the two connections, fulfilling the requirements of Regulation No. 44 or Regulation No. 129, extending from the ISOFIX child restraint system structure and compatible with an ISOFIX low anchorage."
- 2.21. "*ISOFIX child restraint system*" means a child restraint system, fulfilling the requirements of Regulation No. 44 or Regulation No. 129, which has to be attached to an ISOFIX anchorages system."
- 2.22. "*Static force application device (SFAD)*" means a test fixture that engages the vehicle ISOFIX anchorages systems and that is used to verify their strength and the ability of the vehicle or seat structure to limit the rotation in a static test. The test fixture for lower anchorages and top tethers is described in the Figures 1 and 2 annex 9, as well as an SFAD_{SL} (Support Leg) to assess i-Size seating positions with regard to the vehicle floor strength. An example for such an SFAD_{SL} is given in Figure 3 of Annex 10."
- 2.23. "*Anti-rotation device*":
- (a) An anti-rotation device for an ISOFIX universal child restraint system consists of the ISOFIX top-tether.
 - (b) An anti-rotation device for an ISOFIX semi-universal child restraint system consists of either a top tether, the vehicle dashboard or a support leg intended to limit the rotation of the restraint during a frontal impact.
 - (c) An anti-rotation device for an i-Size child restraint system consists of either a top tether or a support leg intended to limit the rotation of the restraint during a frontal impact.
 - (d) For ISOFIX, i-Size, universal and semi-universal, child restraint systems the vehicle seat itself does not constitute an anti-rotation device."
- 2.24. "*ISOFIX top tether anchorage*" means a feature, such as a bar, located in a defined zone, designed to accept an ISOFIX top tether strap connector and transfer its restraint force to the vehicle structure.
- 2.25. "*ISOFIX top tether connector*" means a device intended to be attached to an ISOFIX top tether anchorage.
- 2.26. "*ISOFIX top tether hook*" means an ISOFIX top tether connector typically used to attach an ISOFIX top tether strap to an ISOFIX top tether anchorage as defined in Figure 3 of Annex 9 of this Regulation.
- 2.27. "*ISOFIX top tether strap*" means a webbing strap (or equivalent) which extends from the top of an ISOFIX child restraint system to the ISOFIX top tether anchorage, and which is equipped with an adjustment device, a tension-relieving device, and an ISOFIX top tether connector.

- 2.28. "A guidance device" is intended to help the person installing the ISOFIX child restraint system by physically guiding the ISOFIX attachments on the ISOFIX child restraint into correct alignment with the ISOFIX low anchorages to facilitate engagement.
- 2.29. "A *child restraint fixture*" means a fixture according to one out of the eight ISOFIX size classes defined in paragraph 4. of Annex 17 – Appendix 2 of Regulation No. 16 and particularly whose dimensions are given from Figure 1 to Figure 7 in the previous mentioned paragraph 4. Those child restraint fixtures (CRF) are used in Regulation No. 16, to check what are the ISOFIX child restraint systems size classes which can be accommodated on the vehicle ISOFIX positions. Also one of the CRF, so-called either ISO/F2 (B) or ISO/F2X(B1) which is described in Regulation No. 16 (Annex 17, Appendix 2), is used in this Regulation to check the location and the possibility of access to any ISOFIX anchorages system.
- "2.30. "*Support leg foot assessment volume*" means the volume, as shown in Figures 1 and 2 of Annex 10 of this Regulation, in which the support leg foot of an i-Size child restraint system defined in Regulation No. 129 will rest and therefore the vehicle floor has to intersect.
- 2.31. "*Vehicle floor contact surface*" means the area which results from the intersection of the upper surface of the vehicle floor (incl. trim, carpet, foam, etc.) with the support leg foot assessment volume and is designed to withstand the support leg forces of an i-Size child restraint system defined in Regulation No. 129.
- 2.32. "'*i-Size seating position*" means a seating position, if any defined by the vehicle manufacturer, which is designed to accommodate i-Size child restraint systems and fulfils the requirements defined in this Regulation."

3. Application for approval

- 3.1. The application for approval of a vehicle type with regard to the belt anchorages, the ISOFIX anchorages systems, the ISOFIX top tether anchorages and i-Size seating positions, if any, shall be submitted by the vehicle manufacturer or by his duly accredited representative."
- 3.2. It shall be accompanied by the under mentioned documents in triplicate and by the following particulars:
- 3.2.1. Drawings of the general vehicle structure on an appropriate scale, showing the positions of the belt anchorages, of the effective belt anchorages (where appropriate), of the ISOFIX anchorages systems, of ISOFIX top tether anchorages if any and in case of i-Size seating positions, the vehicle floor contact surface and detailed drawings of the belt anchorages, of the ISOFIX anchorages systems if any, of the ISOFIX top tether anchorage if any, and of the points to which they are attached and in case of i-Size seating positions, the vehicle floor contact surface;"
- 3.2.2. A specification of the materials used which may affect the strength of the belt anchorages, of the ISOFIX anchorages systems and ISOFIX top tether anchorages if any and in case of i-Size seating positions, the vehicle floor contact surface;"

- 3.2.3. A technical description of the belt anchorages, of the ISOFIX anchorages systems and ISOFIX top tether anchorages if any;
- 3.2.4. In the case of belt anchorages, of the ISOFIX anchorages systems and of ISOFIX top tether anchorages if any affixed to the seat structure:
 - 3.2.4.1. Detailed description of the vehicle type with regard to the design of the seats, of the seat anchorages and of their adjustment and locking systems;
 - 3.2.4.2. Drawings, on an appropriate scale and in sufficient detail, of the seats, of their anchorage to the vehicle, and of their adjustment and locking systems.
- 3.2.5. Evidence that the safety-belt or the restraint system used in the anchorages approval test complies with Regulation No. 16, in the case where the car manufacturer chooses the alternative dynamic strength test.
- 3.3. At the option of the manufacturer, a vehicle representative of the vehicle type to be approved or the parts of the vehicle considered essential for the belt anchorages test, for the ISOFIX anchorages systems, of ISOFIX top tether anchorages test if any and in case of i-Size seating positions, the vehicle floor contact surface test, by the technical service conducting approval tests shall be submitted to the service."

4. Approval

- 4.1. If the vehicle submitted for approval pursuant to this Regulation meets the relevant requirements of this Regulation, approval of that vehicle type shall be granted.
- 4.2. An approval number shall be assigned to each type approved. Its first two digits (at present 07, corresponding to the 07 series of amendments) shall indicate the series of amendments incorporating the most recent major technical amendments made to the Regulation at the time of issue of the approval. The same Contracting Party may not assign the same number to another vehicle type as defined in paragraph 2.2. above.
- 4.3. Notice of approval or of extension or refusal or withdrawal of approval or production definitely discontinued of a vehicle type pursuant to this Regulation shall be communicated to the Parties to the 1958 Agreement which apply this Regulation by means of a form conforming to the model in Annex 1 to the Regulation.
- 4.4. There shall be affixed, conspicuously and in a readily accessible place specified on the approval form, to every vehicle conforming to a vehicle type approved under this Regulation an international approval mark consisting of:
 - 4.4.1. A circle surrounding the letter "E" followed by the distinguishing number of the country which has granted approval²;
 - 4.4.2. The number of this Regulation, to the right of the circle prescribed in paragraph 4.4.1.

² The distinguish numbers of the Contracting Parties to the 1958 Agreement are reproduced in Annex 3 to Consolidated Resolution on the Construction of Vehicles (R.E.3), document ECE/TRANS/WP.29/78/Rev.2/Amend.3.

- 4.4.3. The letter "e", to the right of the number of this Regulation in the case of type approval according to the dynamic test of Annex 7.
- 4.5. If the vehicle conforms to a vehicle type approved, under one or more other Regulations Annexed to the Agreement, in the country which has granted approval under this Regulation, the symbol prescribed in paragraph 4.4.1. need not be repeated; in such a case the additional numbers and symbols of all the Regulations under which approval has been granted in the country which has granted approval under this Regulation shall be placed in vertical columns to the right of the symbol prescribed in paragraph 4.4.1.
- 4.6. The approval mark shall be clearly legible and be indelible.
- 4.7. The approval mark shall be placed close to or on the vehicle data plate affixed by the manufacturer.
- 4.8. Annex 2 to this Regulation gives examples of arrangements of the approval mark.

5. Specifications

- 5.1. Definitions (see Annex 3)
 - 5.1.1. The H point is a reference point as defined in paragraph 2.3. of Annex 4 of this Regulation, which must be determined in accordance with the procedure set out in that Annex.
 - 5.1.1.1. Point H' is a reference point corresponding to H as defined in paragraph 5.1.1. which shall be determined for every normal position in which the seat is used.
 - 5.1.1.2. The R point is the seating reference point defined in paragraph 2.4. of Annex 4 of this Regulation.
 - 5.1.2. The three-dimensional reference system is defined in Appendix 2 of Annex 4 of this Regulation.
 - 5.1.3. Points L₁ and L₂ are the lower effective belt anchorages.
 - 5.1.4. Point C is a point situated 450 mm vertically above the R point. However, if the distance S as defined in paragraph 5.1.6. is not less than 280 mm and if the alternative formula $BR = 260 \text{ mm} + 0.8 S$ specified in paragraph 5.4.3.3. is chosen by the manufacturer, the vertical distance between C and R shall be 500 mm.
 - 5.1.5. The angles α_1 and α_2 are respectively the angles between a horizontal plane and planes perpendicular to the median vertical longitudinal plane of the seat and passing through the R-point and the points L₁ and L₂.

If the seat is adjustable, this requirement shall be fulfilled also for the H-points of all normal driving or riding positions, as indicated by the vehicle manufacturer."
 - 5.1.6. S is the distance in millimetres of the effective upper belt anchorages from a reference plane P parallel to the longitudinal median plane of the vehicle defined as follows:
 - 5.1.6.1. If the seating position is well-defined by the shape of the seat, the plane P shall be the median plane of this seat.

- 5.1.6.2. In the absence of a well-defined position:
- 5.1.6.2.1. The plane P for the driver's seat is a vertical plane parallel to the median longitudinal plane of the vehicle which passes through the centre of the steering-wheel in the plane of the steering-wheel rim when the steering-wheel, if adjustable, is in its central position.
- 5.1.6.2.2. The plane P for the front outboard passenger shall be symmetrical with that of the driver.
- 5.1.6.2.3. The plane P for the rear outboard seating position shall be that specified by the manufacturer on condition the following limits for distance A between the longitudinal median plane of the vehicle and plane P are respected:
- A Is equal or more than 200 mm if the bench seat has been designed to accommodate two passengers only,
- A Is equal or more than 300 mm if the bench seat has been designed to accommodate more than two passengers.
- 5.2. General specifications
- 5.2.1. Anchorages for safety-belts shall be so designed, made and situated as to:
- 5.2.1.1. Enable the installation of a suitable safety-belt. The belt anchorages of the front outboard positions shall be suitable for safety-belts incorporating a retractor and pulley, taking into consideration in particular the strength characteristics of the belt anchorages, unless the manufacturer supplies the vehicle equipped with other types of safety-belts which incorporate retractors. If the anchorages are suitable only for particular types of safety-belts, these types shall be stated on the form mentioned in paragraph 4.3. above;
- 5.2.1.2. Reduce to a minimum the risk of the belt's slipping when worn correctly;
- 5.2.1.3. Reduce to a minimum the risk of strap damage due to contact with sharp rigid parts of the vehicle or seat structures;
- 5.2.1.4. Enable the vehicle, in normal use, to comply with the provisions of this Regulation;
- 5.2.1.5. For anchorages which take up different positions to allow persons to enter the vehicle and to restrain the occupants, the specifications of this Regulation shall apply to the anchorages in the effective restraint position.
- 5.2.2. Any ISOFIX anchorages system and any ISOFIX top tether anchorage, installed or intended to be installed, for ISOFIX child restraint systems, as well as the vehicle floor contact surface of any i-Size seating positions, shall be so designed, made and situated as to:"
- 5.2.2.1. Any ISOFIX anchorages system and any top tether anchorage, as well as the vehicle floor contact surface of any i-Size seating positions, shall enable the vehicle, in normal use, to comply with the provisions of this Regulation.
- Any ISOFIX anchorages system and ISOFIX top tether anchorage which could be added on any vehicle shall also comply with the provisions of this Regulation. Consequently, such anchorages shall be described on the application document for type approval.

- 5.2.2.2. ISOFIX anchorages system and ISOFIX top tether anchorage resistance are designed for any ISOFIX child restraint systems of group of mass 0; 0+; 1 as defined in Regulation No. 44.
- 5.2.2.3. An ISOFIX anchorage system, ISOFIX top tether anchorage and vehicle floor contact surface of i-Size seating positions shall be designed for i-Size child restraint system as defined in Regulation No. 129."
- 5.2.3. ISOFIX anchorage systems, design and positioning:
- 5.2.3.1. Any ISOFIX anchorages system shall be 6 mm ± 0.1 mm diameter transverse horizontal rigid bar(s) which cover(s) two zones of 25 mm minimum effective length located on the same axis as defined in Figure 4 Annex 9.
- 5.2.3.2. Any ISOFIX anchorages system installed on a vehicle seating position shall be located not less than 120 mm behind the design H-point as determined in Annex 4 to this Regulation, measured horizontally and up to the centre of the bar.
- 5.2.3.3. For any ISOFIX anchorages system installed in the vehicle, it shall be possible to attach either the ISOFIX child restraint fixture "ISO/F2" (B) or "ISO/F2X" (B1) as defined by the vehicle manufacturer, described in Regulation No. 16 (Annex 17, Appendix 2).

i-Size positions shall accommodate ISOFIX child restraint fixtures of size classes "ISO/F2X" (B1), and "ISO/R2" (D) together with the support leg installation assessment volume, as defined in Regulation No. 16 (Annex 17, Appendix 2)."
- 5.2.3.4. The bottom surface of the ISOFIX child restraint fixture as defined by vehicle manufacturer in paragraph 5.2.3.3., shall have attitude angles within the following limits, angles measured relatively to the vehicle reference planes as defined in Annex 4 – Appendix 2 to this Regulation:
- (a) Pitch: 15° ± 10°,
 - (b) Roll: 0° ± 5°,
 - (c) Yaw: 0° ± 10°
- For i-Size positions, providing the limits specified in paragraph 5.2.3.4. are not exceeded, it is acceptable for the shortest support-leg length, according to the support-leg foot assessment volume, to result in a pitch angle greater than would otherwise be imposed by the vehicle seat or structure. It shall be possible to install the ISOFIX child restraint fixture under the increased pitch angle."
- 5.2.3.5. ISOFIX anchorage systems shall be permanently in position or storable. In case of storable anchorages, the requirements relating to ISOFIX anchorages system shall be fulfilled in the deployed position.
- 5.2.3.6. Each ISOFIX low anchorage bar (when deployed for use) or each permanently installed guidance device shall be visible, without the compression of the seat cushion or seat back, when the bar or the guidance device is viewed, in a vertical longitudinal plane passing through the centre of the bar or of the guidance device, along a line making an upward angle of 30 degrees with a horizontal plane.

As an alternative to the above requirement, the vehicle shall be permanently marked adjacent to each bar or guidance device. This marking shall consist in one of the following, at the choice of the manufacturer.

- 5.2.3.6.1. As a minimum, the symbol of Annex 9, Figure 12 consisting of a circle with a diameter of minimum 13 mm and containing a pictogram, meeting the following conditions:
- (a) The pictogram shall contrast with the background of the circle;
 - (b) The pictogram shall be located close to each bar of the system;
- 5.2.3.6.2. The word "ISOFIX" in capital letters of at least 6 mm height.
- 5.2.3.7. The requirements of paragraph 5.2.3.6. do not apply to the i-Size seating position. i-Size seating positions shall be marked according to paragraph 5.2.5.1."
- 5.2.4. ISOFIX top tether anchorages, design and positioning:
- At the request of the car manufacturer, methods described in paragraphs 5.2.4.1. and 5.2.4.2. can be used alternatively.
- Method described in paragraph 5.2.4.1. can only be used if the ISOFIX position is located on a vehicle seat.
- 5.2.4.1. Subject to paragraphs 5.2.4.3. and 5.2.4.4., the portion of each ISOFIX top tether anchorage that is designed to bind with an ISOFIX top tether connector shall be located not further than 2,000 mm far from the shoulder reference point and within the shaded zone, as shown in Figures 6 to 10 of Annex 9, of the designated seating position for which it is installed, with the reference of a template described in SAE J 826 (July 1995) and shown in Annex 9, Figure 5, according to the following conditions:
- 5.2.4.1.1. The "H" point of the template is located at the unique design "H" point of the full downward and full rearward position of the seat, except that the template is located laterally midway between the two ISOFIX lower anchorages;
 - 5.2.4.1.2. The torso line of the template is at the same angle to the transverse vertical plane as the seat back in its most upright position, and
 - 5.2.4.1.3. The template is positioned in the vertical longitudinal plane that contains the H-point of the template.
- 5.2.4.2. The ISOFIX top tether anchorage zone may be alternatively located with the aid of the Fixture "ISO/F2" (B), as defined in Regulation No. 16 (Annex 17, Appendix 2, Figure 2), in an ISOFIX position equipped with ISOFIX low anchorages as shown in Figure 11 of Annex 9.
- The seating position shall be the seat's rearmost, down most position with the seat back in its nominal position, or as recommended by the vehicle manufacturer.
- In the side view, the ISOFIX top tether anchorage shall lie behind the "ISO/F2" (B) fixture rear face.
- The intersection between the "ISO/F2" (B) fixture rear face and the horizontal line (Annex 9, Figure 11, reference 3) containing the last rigid point of a hardness greater than 50 Shore A at the top of the seat back defines the reference point 4 (Annex 9, Figure 11) on the centreline of the

"ISO/F2" (B) fixture. At this reference point, a maximum angle of 45° above the horizontal line defines the upper limit of the top tether anchorage zone.

In the top view, at the reference point 4 (Annex 9, Figure 11), a maximum angle of 90° extending rearward and laterally and in the rear view, a maximum angle of 40° defines 2 volumes which limit the anchorage zone for the ISOFIX top tether.

The origin of the ISOFIX top tether strap (5) is located at the intersection of the "ISO/F2" (B) fixture with a plane 550 mm distant above the "ISO/F2" (B) fixture horizontal face (1) on the "ISO/F2" (B) fixture centreline (6).

Further, the ISOFIX top tether anchorage shall be more than 200 mm but not more than 2000 mm from the origin of the ISOFIX top tether strap on the rear face of the "ISO/F2" (B) fixture, measured along the strap when it is drawn over the seat back to the ISOFIX top tether anchorage.

- 5.2.4.3. The portion of the ISOFIX top tether anchorage in a vehicle that is designed to bind with the ISOFIX top tether connector may be located outside the shaded zones referred to paragraphs 5.2.4.1. or 5.2.4.2. if a location within a zone is not appropriate and the vehicle is equipped with a routing device that,
 - 5.2.4.3.1. Ensures that the ISOFIX top tether strap functions as if the portion of the anchorage designed to bind with the ISOFIX top tether anchorage were located within the shaded zone; and,
 - 5.2.4.3.2. Is at least 65 mm behind the torso line, in case of a non-rigid webbing-type routing device or a deployable routing device, or at least 100 mm behind the torso line, in the case of a fixed rigid routing device; and,
 - 5.2.4.3.3. When tested after being installed as it is intended to be used, the device is of sufficient strength to withstand, with the ISOFIX top tether anchorage the load referred to in paragraph 6.6. of this Regulation.
- 5.2.4.4. A tether anchorage may be recessed in the seat back, provided that it is not in the strap wrap-around area at the top of the vehicle seat back.
- 5.2.4.5. The ISOFIX top tether anchorage shall have dimensions to permit the attachment of an ISOFIX top tether hook as specified in Figure 3.

Clearance shall be provided around each ISOFIX top tether anchorage to allow latching and unlatching to it.

All anchorages located rearward of any ISOFIX anchorages system and which could be used to attach an ISOFIX top tether hook or ISOFIX top tether connector shall be designed to prevent misuse by one or more of the following measures:

- (a) Designing all such anchorages in the ISOFIX top tether anchorage zone as ISOFIX top tether anchorages; or
- (b) Marking only the ISOFIX top tether anchorages using one of the symbols, or its mirror image, as set out in Figure 13 of Annex 9; or
- (c) Marking such anchorages not in accordance with (a) or (b) above with a clear indication that these anchorages should not be used in combination with any ISOFIX anchorages system.

For each ISOFIX top tether anchorage under a cover, the cover shall be identified by for example one of the symbols or the mirror image of one of

the symbols set out in Figure 13 of Annex 9; the cover shall be removable without the use of tools.

5.2.5. i-Size seating position requirements

Each i-Size seating position, as defined by the vehicle manufacturer, shall conform to the requirements defined in paragraphs 5.2.2. to 5.2.5.3."

5.2.5.1. Markings

Each i-Size seating position shall be permanently marked adjacent to the ISOFIX low anchorages system (bar or guidance device) of the respective seating position.

The minimum marking shall be the symbol of Annex 10, Figure 4 consisting of a square with a minimum size of 13 mm and containing a pictogram and meeting the following conditions:

- (a) The pictogram shall contrast with the background of the square;
- (b) The pictogram shall be located close to each bar of the system.

5.2.5.2. Geometrical requirements for i-Size seating positions connected to i-Size support legs.

In addition to the requirements defined in 5.2.3. and 5.2.4. it shall be verified that the upper surface of the vehicle floor (incl. trim, carpet, foam, etc.) intersects with both of the limiting surfaces in the x- and y-directions of the support leg foot assessment volume, as shown in figures 1 and 2 of Annex 10 to this Regulation.

The support leg foot assessment volume is characterized as follows (see also Annex 10, Figures 1 and 2 of this Regulation):

- (a) In width, by the two planes parallel to and 100 mm apart from the median longitudinal plane of the child restraint fixture installed in the respective seating position; and
- (b) In length, by the two planes perpendicular to the plane given by the child restraint fixture bottom surface and perpendicular to the median longitudinal plane of the child restraint fixture, 585 mm and 695 mm apart from the plane passing through the centerlines of the ISOFIX lower anchorages and being perpendicular to the CRF bottom surface; and
- (c) In height, by two planes which are parallel to and 270 mm and 525 mm below the child restraint bottom surface.

The pitch angle used for the geometrical assessment above shall be measured as in paragraph 5.2.3.4.

Compliance with this requirement may be proven by a physical test or computer simulation or representative drawings.

5.2.5.3. Vehicle floor strength requirements for i-Size seating positions.

The entire vehicle floor contact surface (see Annex 10, Figures 1 and 2) shall be of sufficient strength to withstand the loads imposed when tested in accordance with paragraph 6.6.4.5."

5.3. Minimum number of belt and ISOFIX anchorages to be provided

- 5.3.1. Any vehicle in categories M and N (except those vehicles of categories M₂ or M₃ which belong to Classes I or A¹) shall be equipped with safety-belt anchorages which satisfy the requirements of this Regulation.
- 5.3.1.1. The anchorages of a harness belt system approved as a S-type belt (with or without retractor(s)) according to Regulation No. 16 shall comply with the requirements of Regulation No. 14, but the additional anchorage or anchorages provided for the fitting of a crotch strap (assembly) are exempted from the strength and location requirements of this Regulation.
- 5.3.2. The minimum number of safety-belt anchorages for each forward rearward and side-facing seating position shall be those specified in Annex 6.
- 5.3.3. However, for outboard seating positions, other than front, of vehicles of category N₁, shown in Annex 6 and marked with the symbol Ø, two lower anchorages are allowed, where there exists a passage between a seat and the nearest side-wall of the vehicle intended to permit access of passengers to other parts of the vehicle.
- A space between a seat and the side-wall is considered as a passage if the distance between that side-wall, with all doors closed, and a vertical longitudinal plane passing through the centre line of the seat concerned, measured at the R point position and perpendicularly to the median longitudinal plane of the vehicle is more than 500 mm.
- 5.3.4. For the front centre seating positions shown in Annex 6 and marked with the symbol *, two lower anchorages shall be considered adequate where the windscreen is located outside the reference zone defined in Annex 1 to Regulation No. 21; if located inside the reference zone, three anchorages are required.
- As regards belt anchorages, the windscreen is considered as part of the reference zone when it is capable of entering into static contact with the test apparatus according to the method described in Annex 1 to Regulation No. 21.
- 5.3.5. In every seating position marked in Annex 6 with symbol $\frac{1}{2}$, three anchorages shall be provided. Two anchorages may be provided if one of the following conditions is fulfilled:
- 5.3.5.1. There is a seat or other parts of the vehicle conforming to Regulation No. 80, Appendix 1, paragraph 3.5. directly in front, or
- 5.3.5.2. No part of the vehicle is in the reference zone, or capable of being in the reference zone when the vehicle is in motion, or
- 5.3.5.3. Parts of the vehicle within the said reference zone comply with the energy absorbing requirements set out in Regulation No. 80, Appendix 6.
- 5.3.6. For all seats, intended solely for use or seating intended solely for use when the vehicle is stationary as well as for all the seats of any vehicle which are not covered by paragraphs 5.3.1. to 5.3.4., no belt anchorages are required. However, if the vehicle is fitted with anchorages for such seats, these anchorages must comply with the provisions of this Regulation. Any anchorage intended solely for use in conjunction with a disabled person's belt, or any other restraint system according to Regulation No. 107, 02 series of amendments, Annex 8, do not need to conform to the requirements of this Regulation.

- 5.3.7. In the case of the upper deck of a double-deck vehicle, the requirements for the centre front seating position shall apply also in the outboard front seating positions.
- 5.3.8. Minimum number of ISOFIX positions to be provided:
- 5.3.8.1. Any vehicle of category M₁ shall be equipped at least with two ISOFIX positions which satisfy the requirements of this Regulation.
At least two of the ISOFIX positions shall be equipped both with an ISOFIX anchorages system and an ISOFIX top tether anchorage.
The type and number of ISOFIX fixtures, defined in Regulation No. 16, which can be installed on each ISOFIX position are defined in Regulation No. 16.
- 5.3.8.2. Notwithstanding paragraph 5.3.8.1. if a vehicle is only equipped with one seat row, no ISOFIX position is required.
- 5.3.8.3. Notwithstanding paragraph 5.3.8.1. at least one of the two ISOFIX positions systems shall be installed at the second seat row.
- 5.3.8.4. Notwithstanding paragraph 5.3.8.1. vehicles of category M₁ need to have only one ISOFIX position system for vehicles with:
- (a) Not more than two passenger doors and
 - (b) A rear designated seating position for which interference with transmission and/or suspension components prevents the installation of ISOFIX anchorages according to the requirements of paragraph 5.2.3 and
 - (c) Having a Power to mass ratio index (PMR) exceeding 140 according to the definitions within Regulation No. 51, and with the definition of the Power Mass Ratio (PMR):
$$PMR = (P_n / m_t) * 1000 \text{ kg/kW}$$
where:
P_n: maximum (rated) engine power expressed in kW³
m_{ro}: mass of a vehicle in running order expressed in kg
m_t = m_{ro} (for vehicles of category M₁)
and
 - (d) Having an engine developing a maximum (rated) engine power greater than 200 kW³.
- Such a vehicle needs to have only one ISOFIX anchorages system and an ISOFIX top tether anchorage at a front passenger designated seating position combined with an airbag deactivation device (if that seating position is fitted with an airbag) and a caution label indicating that there is no ISOFIX position system available at the second seat row.
- 5.3.8.5. If an ISOFIX anchorages system is installed at a front seating position protected with a frontal airbag, a de-activation device for this airbag shall be fitted.

³ (Rated) engine power means the engine power expressed in kW (ECE) and measured by the ECE method pursuant to Regulation No. 85.

- 5.3.8.6. Notwithstanding paragraph 5.3.8.1. in case of integrated "built in" child restraint system(s) the number of ISOFIX positions to be provided shall be at least two minus the number of the integrated "built in" child restraint system(s) of mass groups 0, or 0+, or 1.
- 5.3.8.7. Convertible vehicles as defined in paragraph 2.9.1.5. of the Consolidated Resolution on the Construction of Vehicles (R.E.3) with more than one seat row shall be fitted with at least two ISOFIX low anchorages. In case where an ISOFIX top tether anchorage is provided on such vehicles, it shall comply with the suitable provisions of this Regulation."
- 5.3.8.8. If a vehicle is only equipped with one seat position per row, only one ISOFIX position is required in the passenger position. In case where an ISOFIX top tether anchorage is provided on such vehicles, it shall comply with the suitable provisions of this Regulation. However, where it is not possible to install even the smallest forward-facing ISOFIX fixture (as defined in Regulation No. 16, Appendix 2, of Annex 17) in the passenger seating position, then no ISOFIX position shall be required, provided that a child restraint system is specified for that vehicle."
- 5.3.8.9. Notwithstanding paragraph 5.3.8.1. above, ISOFIX positions are not required in ambulances or hearses as well as vehicles intended for use by the armed services, civil defence, fire services and forces responsible for maintaining public order."
- 5.3.8.10. Notwithstanding the provisions of paragraph 5.3.8.1. to 5.3.8.4., one or more of the mandatory ISOFIX positions may be replaced by i-Size seating positions."
- 5.3.9. In the case of seats capable of being turned to or placed in other orientations, for use when the vehicle is stationary, the requirements of paragraph 5.3.1. shall apply only to those orientations designated for normal use when the vehicle is travelling on a road, in accordance with this Regulation. A note to this effect shall be included in the information document.
- 5.4. Location of belt anchorages (see Annex 3, Figure 1.)
- 5.4.1. General
- 5.4.1.1. The belt anchorages for any one belt may be located either wholly in the vehicle structure or in the seat structure or any other part of the vehicle or dispersed between these locations.
- 5.4.1.2. Any one belt anchorage may be used for attaching the ends of two adjacent safety-belts, provided that the test requirements are met.
- 5.4.2. Location of the effective lower belt anchorage
- 5.4.2.1. Front seats, vehicle category M₁
- In motor vehicles of category M₁ the angle α_1 (other than buckle side) shall be within the range of 30 to 80 degrees and the angle α_2 (buckle side) shall be within the range of 45 to 80 degrees. Both angle requirements shall be valid for all normal travelling positions of the front seats. Where at least one of the angles α_1 and α_2 is constant (e.g. anchorage fixed at the seat) in all normal positions of use, its value shall be $60 \pm 10^\circ$. In the case of adjustable seats with an adjusting device as described in paragraph 2.12. with a seatback angle of less than 20° (see Annex 3, Figure 1), the angle α_1 may be below the minimum value (30°) stipulated above, provided it is not less than 20° in any normal position of use.

- 5.4.2.2. Rear seats, vehicle category M_1
- In motor vehicles of category M_1 the angles α_1 and α_2 shall be within the range of 30 to 80 degrees for all rear seats. If rear seats are adjustable the above angles shall be valid for all normal travelling positions.
- 5.4.2.3. Front seats, vehicle categories other than M_1
- In motor vehicles of categories other than M_1 the angles α_1 and α_2 must be between 30 and 80 degrees for all normal travelling positions of the front seats. Where in the case of front seats of vehicles having a maximum vehicle mass not exceeding 3.5 tonnes at least one of the angles α_1 and α_2 is constant in all normal positions of use, its value shall be $60 \pm 10^\circ$ (e.g. anchorage fixed at the seat).
- 5.4.2.4. Rear seats and special front or rear seats, vehicle categories other than M_1
- In vehicles of categories other than M_1 , in the case of:
- (a) Bench seats,
 - (b) Adjustable seats (front and rear) with an adjusting system with a seatback angle of less than 20° (see Annex 3, Figure 1), and
 - (c) Other rear seats,
- Angles α_1 and α_2 may be between 20° and 80° in any normal position of use. Where in the case of front seats of vehicles having a maximum vehicle mass not exceeding 3.5 tonnes at least one of the angles α_1 and α_2 is constant in all normal positions of use, its value shall be $60 \pm 10^\circ$ (e.g. anchorage fixed at the seat).
- In the case of seats, other than front seats, of vehicles in categories M_2 and M_3 , the angles α_1 and α_2 shall be between 45 and 90 degrees for all normal positions of use.
- 5.4.2.5. The distance between the two vertical planes parallel to the median vertical longitudinal plane of the vehicle and each passing through a different one of the two effective lower belt anchorages L_1 and L_2 of the same safety-belt shall not be less than 350 mm. In the case of side-facing seats the distance between the two vertical planes parallel to the median vertical longitudinal plane of the seat and each passing through a different one of the two effective lower belt anchorages L_1 and L_2 of the same safety-belt shall not be less than 350 mm. In the case of any central seating positions in rear rows of seats of vehicles of category M_1 and N_1 , the above-mentioned distance shall be not less than 240 mm, provided that it is not possible to exchange the centre rear seat with any of the other seats of the vehicle. The median longitudinal plane of the seat shall pass between points L_1 and L_2 and shall be at least 120 mm from these points.
- 5.4.3. Location of the effective upper belt anchorages (see Annex 3)
- 5.4.3.1. If a strap guide or similar device is used which affects the location of the effective upper belt anchorage, this location shall be determined in a conventional way by considering the position of the anchorage when the longitudinal centre line of the strap passes through a point J_1 defined successively from the R point by the following three segments:
- RZ: A segment of the torso line measured in an upward direction from R and 530 mm long;

ZX: A segment perpendicular to the median longitudinal plane of the vehicle, measured from point Z in the direction of the anchorage and 120 mm long;

XJ₁: A segment perpendicular to the plane defined by segments RZ and ZX, measured in a forward direction from point X and 60 mm long.

Point J₂ is determined by symmetry with point J₁ about the longitudinal vertical plane passing through the torso line described in paragraph 5.1.2. of the manikin positioned in the seat in question.

Where a two-door configuration is used to provide access to both the front and rear seats and the upper anchorage is fitted to the "B" post, the system must be designed so as not to impede access to or egress from the vehicle.

- 5.4.3.2. The effective upper anchorage shall lie below the plane FN, which runs perpendicular to the longitudinal median plane of the seat and makes an angle of 65° with the torso line. The angle may be reduced to 60° in the case of rear seats. The plane FN shall be so placed as to intersect the torso line at a point D such that $DR = 315 \text{ mm} + 1.8 S$. However, when $S \leq 200 \text{ mm}$, then $DR = 675 \text{ mm}$.
- 5.4.3.3. The effective upper belt anchorage shall lie behind a plane FK running perpendicular to the longitudinal median plane of the seat and intersecting the torso line at an angle of 120° at a point B such that $BR = 260 \text{ mm} + S$. Where $S \geq 280 \text{ mm}$, the manufacturer may use $BR = 260 \text{ mm} + 0.8 S$ at his discretion.
- 5.4.3.4. The value of S shall not be less than 140 mm.
- 5.4.3.5. The effective upper belt anchorage shall be situated to the rear of a vertical plane perpendicular to the median longitudinal plane of the vehicle and passing through the R point as shown in Annex 3.
- 5.4.3.6. The effective upper belt anchorage shall be situated above a horizontal plane passing through point C defined in paragraph 5.1.4.
- 5.4.3.6.1. Notwithstanding the requirements of paragraph 5.4.3.6 the effective upper belt anchorage for passenger seats of category M₂ and M₃ vehicles may be adjustable below that specification providing the following requirements are met:
- (a) The safety belt or seat shall be permanently marked to identify the position of the effective upper belt anchorage that is required to satisfy the minimum upper anchorage height position required by paragraph 5.4.3.6. This marking shall clearly indicate to the user when the anchorage is in a position suitable for use by an adult of average stature;
 - (b) The effective upper anchorage shall be so designed to permit adjustment of its height by a manual adjusting device that is readily accessible to the wearer when seated and is convenient and easy to use;
 - (c) The effective upper anchorage shall be so designed to prevent any unintended upward movement of the anchorage that would reduce the effectiveness of the device during normal use;

- (d) The manufacturer shall include within the vehicle handbook clear guidance on the adjustment of such systems, together with advice on the suitability and limitations for use by occupants of short stature."
- 5.4.3.7. In addition to the upper anchorage specified in paragraph 5.4.3.1. other effective upper anchorages may be provided if one of the following conditions is satisfied:
- 5.4.3.7.1. The additional anchorages comply with the requirements of paragraphs 5.4.3.1. to 5.4.3.6.
- 5.4.3.7.2. The additional anchorages can be used without the aid of tools, comply with the requirements of paragraphs 5.4.3.5. and 5.4.3.6. and are located in one of the areas determined by shifting the area shown in Figure 1 of Annex 3 of this Regulation, 80 mm upwards or downwards in a vertical direction.
- 5.4.3.7.3. The anchorage(s) is/are intended for a harness belt, complies/comply with the requirements laid down in paragraph 5.4.3.6. if it lie(s) behind the transverse plane passing through the reference line and is/are located:
- 5.4.3.7.3.1. In the case of a single anchorage, within the area common to two dihedrals defined by the verticals passing through points J_1 and J_2 as defined in paragraph 5.4.3.1. and whose horizontal sections are shown in Figure 2 of Annex 3 of this Regulation;
- 5.4.3.7.3.2. In the case of two anchorages, within whichever of the above defined dihedrals is suitable, provided that each anchorage is not more than 50 mm distant from the symmetrically-located, mirror-image position of the other anchorage about plane P, as defined in paragraph 5.1.6. of the seat in question.
- 5.5. Dimensions of threaded anchorage holes
- 5.5.1. An anchorage shall have a threaded hole of 7/16 inch (20 UNF 2B).
- 5.5.2. If the vehicle is fitted by the manufacturer with safety-belts which are attached to all anchorages prescribed for the seat in question, these anchorages need not meet the requirement set out in paragraph 5.5.1., provided that they comply with the other provisions of this Regulation. In addition, the requirement set out in paragraph 5.5.1. shall not apply to additional anchorages which meet the requirement set out in paragraph 5.4.3.7.3.
- 5.5.3. It shall be possible to remove the safety-belt without damaging the anchorage.

6. Tests

- 6.1. General tests for seat belt anchorages
- 6.1.1. Subject to application of the provisions of paragraph 6.2., and at the request of the manufacturer;
- 6.1.1.1. The tests may be carried out either on a vehicle structure or on a completely finished vehicle;
- 6.1.1.2. The tests may be restricted to the anchorages relating to only one seat or one group of seats on the condition that:

- (a) The anchorages concerned have the same structural characteristics as the anchorages relating to the other seats or group of seats; and
 - (b) Where such anchorages are fitted totally or partially on the seat or group of seats, the structural characteristics of the seat or group of seats are the same as those for the other seats or groups of seats.
- 6.1.1.3. Windows and doors may be fitted or not and closed or not;
- 6.1.1.4. Any fitting normally provided and likely to contribute to the rigidity of the vehicle structure may be fitted.
- 6.1.2. The seats shall be fitted and placed in the position for driving or use chosen by the technical service responsible for conducting approval tests to give the most adverse conditions with respect to the strength of the system. The position of the seats shall be stated in the report. The seat-back shall, if its inclination is adjustable, be locked as specified by the manufacturer or, in the absence of any such specification, in a position corresponding to an effective seat-back angle as close as possible to 25° for vehicles of categories M₁ and N₁ and to 15° for vehicles of all other categories.
- 6.2. Securing the vehicle for seat belt anchorages tests and for ISOFIX anchorages tests
 - 6.2.1. The method used to secure the vehicle during the test shall not be such as to strengthen the seat belt anchorages or the ISOFIX anchorages and their anchorage area or to lessen the normal deformation of the structure.
 - 6.2.2. A securing device shall be regarded as satisfactory if it produces no effect on an area extending over the whole width of the structure and if the vehicle or the structure is blocked or fixed in front at a distance of not less than 500 mm from the anchorage to be tested and is held or fixed at the rear not less than 300 mm from that anchorage.
 - 6.2.3. It is recommended that the structure should rest on supports arranged approximately in line with the axes of the wheels or, if that is not possible, in line with the points of attachment of the suspension.
 - 6.2.4. If a securing method other than that prescribed in paragraphs 6.2.1. to 6.2.3. of this Regulation is used, evidence must be furnished that it is equivalent.
- 6.3. General test requirements for seat belt anchorages
 - 6.3.1. All the belt anchorages of the same group of seats shall be tested simultaneously. However, if there is a risk that non-symmetrical loading of the seats and/or anchorages may lead to failures, an additional test may be carried out with non-symmetrical loading.
 - 6.3.2. The tractive force shall be applied at an angle of 10 degrees ±5° above the horizontal, in a plane parallel to the median longitudinal plane of the vehicle.

A preload of 10 per cent with a tolerance of ±30 per cent of the target load shall be applied; the load shall be increased to 100 per cent of the relevant target load.
 - 6.3.3. Full application of the load shall be achieved as rapidly as possible, and within a maximum load application time of 60 seconds.

However, the manufacturer may request the application of the load to be achieved within 4 seconds.

The belt anchorages must withstand the specified load for not less than 0.2 second.

- 6.3.4. Traction devices to be used in the tests described in paragraph 6.4. below are shown in Annex 5. The devices shown in Annex 5, Figure 1 are placed onto the seat cushion and then, when possible, pushed back into the seat back while the belt strap is pulled tight around it. The device shown in Annex 5, Figure 2 is placed in position, the belt strap is fitted over the device and pulled tight. No preload beyond the minimum necessary for correct positioning of the test device shall be introduced to safety-belt anchorages during this operation.

The traction device of either 254 mm or 406 mm used at each seating position shall be such that its width is as close as possible to the distance between the lower anchorages.

The positioning of the traction device shall avoid any mutual influences during the pull test which adversely affects the load and load distribution.

- 6.3.5. The belt anchorages for seats for which upper belt anchorages are provided shall be tested under the following conditions:

- 6.3.5.1. Front outboard seats:

The belt anchorages shall be submitted to the test prescribed in paragraph 6.4.1. in which the loads are transmitted to them by means of a device reproducing the geometry of a three-point belt equipped with a retractor having a pulley or strap guide at the upper belt anchorage. In addition, if the number of anchorages is more than that prescribed in paragraph 5.3., these anchorages shall be subjected to the test specified in paragraph 6.4.5., in which the loads shall be transmitted to the anchorages by means of a device reproducing the geometry of the type of safety-belt intended to be attached to them.

- 6.3.5.1.1. In the case where the retractor is not attached to the required outboard lower belt anchorage or in the case where the retractor is attached to the upper belt anchorage, the lower belt anchorages shall also be submitted to the test prescribed in paragraph 6.4.3.

- 6.3.5.1.2. In the above case the tests prescribed in paragraphs 6.4.1. and 6.4.3. can be performed on two different structures if the manufacturer so requests.

- 6.3.5.2. Rear outboard seats and all centre seats:

The belt anchorages shall be subjected to the test prescribed in paragraph 6.4.2. in which the loads are transmitted to them by means of a device reproducing the geometry of a three-point safety-belt without a retractor, and to the test prescribed in paragraph 6.4.3., in which the loads are transmitted to the two lower belt anchorages by means of a device reproducing the geometry of a lap belt. The two tests can be performed on two different structures if the manufacturer so requests.

- 6.3.5.3. When a manufacturer supplies his vehicle with safety-belts, the corresponding belt anchorages may, at the request of the manufacturer, be submitted only to a test in which the loads are transmitted to them by means of a device reproducing the geometry of the type of belts to be attached to these anchorages.

- 6.3.6. If no upper belt anchorages are provided for the outboard seats and the centre seats, the lower belt anchorages shall be submitted to the test prescribed in paragraph 6.4.3., in which the loads are transmitted to these anchorages by means of a device reproducing the geometry of a lap belt.
- 6.3.7. If the vehicle is designed to accept other devices which do not enable the straps to be directly attached to belt anchorages without intervening sheaves, etc. or which require belt anchorages supplementary to those mentioned in paragraph 5.3., the safety-belt or an arrangement of wires, sheaves, etc. representing the equipment of the safety-belt, shall be attached by such a device to the belt anchorages in the vehicle and the belt anchorages shall be subjected to the tests prescribed in paragraph 6.4., as appropriate.
- 6.3.8. A test method other than those prescribed in paragraph 6.3. may be used, but evidence must be furnished that it is equivalent.
- 6.4. Particular test requirements for seat belt anchorages
- 6.4.1. Test in configuration of a three-point belt incorporating a retractor having a pulley or strap guide at the upper belt anchorage
- 6.4.1.1. A special pulley or guide for the wire or strap appropriate to transmit the load from the traction device, or the pulley or strap guide supplied by the manufacturer shall be fitted to the upper belt anchorage.
- 6.4.1.2. A test load of $1,350 \text{ daN} \pm 20 \text{ daN}$ shall be applied to a traction device (see Annex 5, Figure 2) attached to the belt anchorages of the same belt, by means of a device reproducing the geometry of the upper torso strap of such a safety-belt. In the case of vehicles of categories other than M_1 and N_1 , the test load shall be $675 \pm 20 \text{ daN}$, except that for M_3 and N_3 vehicles the test load shall be $450 \pm 20 \text{ daN}$.
- 6.4.1.3. At the same time a tractive force of $1,350 \text{ daN} \pm 20 \text{ daN}$ shall be applied to a traction device (see Annex 5, Figure 1) attached to the two lower belt anchorages. In the case of vehicles of categories other than M_1 and N_1 , the test load shall be $675 \pm 20 \text{ daN}$, except that for M_3 and N_3 vehicles the test load shall be $450 \pm 20 \text{ daN}$.
- 6.4.2. Test in configuration of a three-point belt without retractor or with a retractor at the upper belt anchorage
- 6.4.2.1. A test load of $1,350 \text{ daN} \pm 20 \text{ daN}$ shall be applied to a traction device (see Annex 5, Figure 2) attached to the upper belt anchorage and to the opposite lower belt anchorage of the same belt using, if supplied by the manufacturer, a retractor fixed at the upper belt anchorage. In the case of vehicles of categories other than M_1 and N_1 , the test load shall be $675 \pm 20 \text{ daN}$, except that for M_3 and N_3 vehicles the test load shall be $450 \pm 20 \text{ daN}$.
- 6.4.2.2. At the same time a tractive force of $1,350 \text{ daN} \pm 20 \text{ daN}$ shall be applied to a traction device (see Annex 5, Figure 1) attached to the lower belt anchorages. In the case of vehicles of categories other than M_1 and N_1 , the test load shall be $675 \pm 20 \text{ daN}$, except that for M_3 and N_3 vehicles the test load shall be $450 \pm 20 \text{ daN}$.
- 6.4.3. Test in configuration of a lap belt
- A test load of $2,225 \text{ daN} \pm 20 \text{ daN}$ shall be applied to a traction device (see Annex 5, Figure 1) attached to the two lower belt anchorages. In the case of vehicles of categories other than M_1 and N_1 , the test load shall be

1,110 ± 20 daN, except that for M₃ and N₃ vehicles the test load shall be 740 ± 20 daN.

6.4.4. Test for belt anchorages located wholly within the seat structure or dispersed between the vehicle structure and the seat structure

6.4.4.1. The test specified in paragraphs 6.4.1., 6.4.2. and 6.4.3. above shall be performed, as appropriate, at the same time superimposing for each seat and for each group of seats a force as stated below.

6.4.4.2. The loads indicated in paragraphs 6.4.1., 6.4.2. and 6.4.3 above shall be supplemented by a force equal to 20 times the mass of the complete seat. The inertia load shall be applied to the seat or to the relevant parts of the seat corresponding to the physical effect of the mass of the seat in question to the seat anchorages. The determination of the additional applied load or loads and the load distribution shall be made by the manufacturer and agreed by the Technical Service.

In the case of vehicles in categories M₂ and N₂, this force must be equal to 10 times the mass of the complete seat; for categories M₃ and N₃ it shall be equal to 6.6 times the mass of the complete seat.

6.4.5. Test in configuration of a special-type belt

6.4.5.1. A test load of 1,350 ± 20 daN shall be applied to a traction device (see Annex 5, Figure 2) attached to the belt anchorages of such a safety-belt by means of a device reproducing the geometry of the upper torso strap or straps.

6.4.5.2. At the same time, a tractive force of 1,350 ± 20 daN shall be applied to a traction device (see Annex 5, Figure 3) attached to the two lower belt anchorages.

6.4.5.3. In the case of vehicles of categories other than M₁ and N₁, this test load shall be 675 ± 20 daN, except that for M₃ and N₃ vehicles the test load shall be 450 ± 20 daN.

6.4.6. Test in the case of rearward-facing seats

6.4.6.1. The anchorage points shall be tested according to the forces prescribed in paragraphs 6.4.1., 6.4.2. or 6.4.3., as appropriate. In each case the test load shall correspond to the load prescribed for M₃ or N₃ vehicles.

6.4.6.2. The test load shall be directed forward in relation to the seating position in question, corresponding to the procedure prescribed in paragraph 6.3.

6.4.7. Test in the case of side-facing seats

6.4.7.1. The anchorage points shall be tested according to the forces prescribed in paragraph 6.4.3. for M₃ vehicles.

6.4.7.2. The test load shall be directed forward in relation to the vehicle, corresponding to the procedure prescribed in paragraph 6.3. In the case that side-facing seats are grouped together on a basic structure, the safety-belt anchorage points of each seating position in the group shall be tested separately. In addition the basic structure has to be tested as described in paragraph 6.4.8.

6.4.7.3. Traction device adapted for the test of side-facing seats is shown in Annex 5, Figure 1b.

- 6.4.8. Test of the basic structure of side-facing seats
- 6.4.8.1. The basic structure of a side-facing seat or a group of side-facing seats shall be tested according to the forces as prescribed in paragraph 6.4.3. for M₃ vehicles.
- 6.4.8.2. The test load shall be directed forward in relation to the vehicle, corresponding to the procedure prescribed in paragraph 6.3. In the case that side-facing seats are grouped together the basic structure shall be tested simultaneously for each seating position in the group.
- 6.4.8.3. The point of application of the forces prescribed in paragraphs 6.4.3. and 6.4.4. shall be as close as possible to the H-Point and on the line defined by a horizontal plane and a vertical transverse plane through the relevant H-Point of each seating position.
- 6.5. In the case of a group of seats as described in paragraph 1. of Annex 7, the dynamic test of Annex 7 can be performed, at the option of the car manufacturer, as an alternative to the static test prescribed in paragraphs 6.3. and 6.4.
- 6.6. Static test requirements.
- 6.6.1. The strength of the ISOFIX anchorage systems shall be tested applying the forces, as prescribed in paragraph 6.6.4.3., to the static force application device (SFAD) with ISOFIX attachments well engaged.
- In case of ISOFIX top tether anchorage an additional test shall be performed as prescribed in paragraph 6.6.4.4.
- In case of an i-Size seating position, an additional support leg test shall be performed as described in paragraph 6.6.4.5.
- All the ISOFIX positions and/or i-Size seating positions of a same seat row, which can be used simultaneously, shall be tested simultaneously."
- 6.6.2. The test may be carried out either on a completely finished vehicle or on sufficient parts of the vehicle so as to be representative of the strength and rigidity of the vehicle structure.
- Windows and doors may be fitted or not and closed or not.
- Any fitting normally provided and likely to contribute to the vehicle structure may be fitted.
- The test may be restricted to the ISOFIX or i-Size position relating to only one seat or group of seats on the condition that:
- (a) The ISOFIX or i-Size position concerned has the same structural characteristics as the ISOFIX or i-Size position relating to the other seats or group of seats and;
- (b) Where such ISOFIX or i-Size positions are fitted totally or partially on the seat or group of seats, the structural characteristics of the seat or group of seats or floor in case of i-Size seating positions are the same as those for the other seats or groups of seats."
- 6.6.3. If the seats and head restraint are adjustable, they shall be tested in the position defined by the technical service within the limited range prescribed by the car manufacturer as provided in Appendix 3 of Annex 17 of Regulation No. 16.

- 6.6.4. Forces, directions and excursion limits.
- 6.6.4.1. A force of $135 \text{ N} \pm 15 \text{ N}$ shall be applied to the centre of the lower front crossbar of the SFAD in order to adjust the fore-aft position of the SFAD rearward extension to remove any slack or tension between the SFAD and its support.
- 6.6.4.2. Forces shall be applied to the static force application device (SFAD) in forward and oblique directions according to Table 1.

Table 1
Directions of test forces

| | | |
|---------|---|------------------------------------|
| Forward | $0^\circ \pm 5^\circ$ | $8 \text{ kN} \pm 0.25 \text{ kN}$ |
| Oblique | $75^\circ \pm 5^\circ$ (to both sides of straight forward, or if any worst case side, or if both side are symmetric, only one side) | $5 \text{ kN} \pm 0.25 \text{ kN}$ |

Each of these tests may be performed on different structures if the manufacturer so requests.

Forces in the forward direction shall be applied with an initial force application angle of $10 \pm 5^\circ$ above the horizontal. Oblique forces shall be applied horizontally $0^\circ \pm 5^\circ$. A pre-load force of $500 \text{ N} \pm 25 \text{ N}$ shall be applied at the prescribed loading point X indicated in Figure 2 of Annex 9. Full application of the load shall be achieved as rapidly as possible, and within a maximum load application time of 30 seconds. However, the manufacturer may request the application of the load to be achieved within 2 seconds. The force shall be maintained for a minimum period of 0.2 s.

All measurements shall be made according to ISO 6487 with CFC of 60 Hz or any equivalent method.

- 6.6.4.3. Tests of ISOFIX anchorages system only:
- 6.6.4.3.1. Forward direction force test:
Horizontal longitudinal excursion (after pre-load) of point X of SFAD during application of the $8 \text{ kN} \pm 0.25 \text{ kN}$ force shall be limited to 125 mm and permanent deformation including partial rupture or breakage of any ISOFIX low anchorage or surrounding area shall not constitute failure if the required force is sustained for the specified time.
- 6.6.4.3.2. Oblique direction force test:
Excursion in the direction of the force (after pre-load) of point X of SFAD during application of the $5 \text{ kN} \pm 0.25 \text{ kN}$ force shall be limited to 125 mm and permanent deformation including partial rupture or breakage of any ISOFIX low anchorage or surrounding area shall not constitute failure if the required force is sustained for the specified time.
- 6.6.4.4. Test of ISOFIX anchorages systems and ISOFIX top tether anchorage:
A tension pre-load of $50 \text{ N} \pm 5 \text{ N}$ must be applied between the SFAD and the top-tether anchorage. Horizontal excursion (after pre-load) of point X during application of the $8 \text{ kN} \pm 0.25 \text{ kN}$ force shall be limited to 125 mm and permanent deformation including partial rupture or breakage of any ISOFIX low anchorage and top tether anchorage, or surrounding area shall not constitute failure if the required force is sustained for the specified time.

Table 2

Excursions limits

| <i>Force direction</i> | <i>Maximum excursion of point X of SFAD</i> |
|------------------------|---|
| Forward | 125 mm longitudinal |
| Oblique | 125 mm force direction |

6.6.4.5. Test for i-Size seating positions:

In addition to the tests specified in paragraphs 6.6.4.3. and 6.6.4.4., a test with a modified static force application device, which consists of a SFAD and includes a support leg test probe as defined in Figure 3 of Annex 10, shall be performed. The support leg test device shall be adjusted in length and width to assess the vehicle floor contact surface, as defined in paragraph 5.2.5.2. (see also Figures 1 and 2 of Annex 10 to this Regulation). The height of the support leg test device shall be adjusted in a way that the foot of the support leg test device is in contact with the upper surface of the vehicle floor. In case of incremental height adjustment, the first notch where the foot rests stable on the floor shall be chosen; in case of a non-incremental/continuous adjustment of the support leg test device height, the pitch angle of the SFAD shall be increased by 1.5 +/- 0.5 degrees due to the height adjustment of the support leg test device.

The horizontal excursion (after pre-load) of point X of the SFAD during application of the 8 kN ± 0.25 kN force shall be limited to 125 mm and permanent deformation including partial rupture or breakage of any ISOFIX low anchorage and the vehicle floor contact surface, or surrounding area shall not constitute failure if the required force is sustained for the specified time."

6.6.5. Additional forces

6.6.5.1. Seat inertia forces.

For the installation position where the load is transferred into a vehicle seat assembly, and not directly into the vehicle structure, a test shall be carried out to ensure that the strength of the vehicle seat anchorages to the vehicle structure is sufficient. In this test, a force equal to 20 times the mass of the relevant parts of the seat assembly shall be applied horizontally and longitudinally in a forward direction to the seat or the relevant part of the seat assembly corresponding to the physical effect of the mass of the seat in question to the seat anchorages. The determination of the additional applied load or loads and the load distribution shall be made by the manufacturer and agreed by the Technical Service.

At the request of the manufacturer, the additional load can be applied at the X point of SFAD during the static tests described above.

If the top tether anchorage is integrated to the vehicle seat, this test shall be performed with the ISOFIX top tether strap.

No breakage shall occur and excursion requirements given in the Table 2 have to be fulfilled.

Note: This test does not have to be performed in case of any anchorage of the vehicle safety-belt system is integrated to the vehicle seat structure, and the vehicle seat is already tested and approved to meet the anchorage load tests required by this Regulation for adult passenger restraint.

7. Inspection during and after static tests for safety-belt anchorages

- 7.1. All the anchorages shall be capable of withstanding the test prescribed in paragraphs 6.3. and 6.4. Permanent deformation, including partial rupture or breakage of any anchorage or surrounding area, shall not constitute failure if the required force is sustained for the specified time. During the test, the minimum spacings for the effective lower belt anchorages specified in paragraph 5.4.2.5. and the requirements of paragraph 5.4.3.6. for effective upper belt anchorages shall be respected.
- 7.1.1. For vehicles of category M_1 of a total permissible mass not exceeding 2.5 tonnes, if the upper safety-belt anchorage is attached to the seat structure, the effective upper safety-belt anchorage shall not be displaced during the test forward of a transverse plane passing through the R point and point C of the seat in question (see Figure 1 of Annex 3 to this Regulation)
- For vehicles other than mentioned above, the effective upper safety-belt anchorage shall not be displaced during the test forward of a transverse plane inclined 10° in forward direction and passing through the R point of the seat.
- The maximum displacement of the effective upper anchorage point shall be measured during the test.
- If the displacement of the effective upper anchorage point exceeds the above-mentioned limitation, the manufacturer shall demonstrate to the satisfaction of the technical service that there is no danger to the occupant. As an example, the test procedure according to Regulation No. 94 or a sled test with corresponding pulse may be carried out to demonstrate a sufficient survival space.
- 7.2. In vehicles where such devices are used, the displacement and locking devices enabling the occupants of all seats to leave the vehicle must still be operable by hand after the tractive force was removed.
- 7.3. After testing any damage to the anchorages and structures supporting load during tests shall be noted.
- 7.4. By derogation, the upper anchorages fitted to one or more seats of vehicles of category M_3 and those of category M_2 with a maximum mass exceeding 3.5 tonnes, which meet the requirements of Regulation No. 80, need not to comply with the requirements of paragraph 7.1. concerning compliance with paragraph 5.4.3.6.

8. Modifications and extension of approval of the vehicle type

- 8.1. Every modification of the vehicle type shall be notified to the Type Approval Authority which approved the vehicle type. The Authority may then either:
- 8.1.1. Consider that the modifications made are unlikely to have an appreciable adverse effect and that in any case the vehicle still complies with the requirements; or
- 8.1.2. Require a further test report from the technical service responsible for conducting the tests.

- 8.2. Confirmation or refusal of approval, specifying the alterations, shall be communicated by the procedure specified in paragraph 4.3. above to the Parties to the Agreement which apply this Regulation.
- 8.3. The competent authority issuing the extension of approval shall assign a series number for such an extension and inform thereof the other Parties to the 1958 Agreement applying this Regulation by means of a communication form conforming to the model in Annex 1 to this Regulation.

9. Conformity of production

The conformity of production procedures shall comply with those set out in the Agreement, Appendix 2 (E/ECE/324-E/ECE/TRANS/505/Rev.2), with the following requirements:

- 9.1. Every vehicle bearing an approval mark as prescribed under this Regulation shall conform to the vehicle type approved with regard to details affecting the characteristics of the safety-belt anchorages and the ISOFIX anchorages system and ISOFIX top tether anchorage.
- 9.2. In order to verify conformity as prescribed in paragraph 9.1. above, a sufficient number of serially-produced vehicles bearing the approval mark required by this Regulation shall be subjected to random checks.
- 9.3. As a general rule the checks as aforesaid shall be confined to the taking of measurements. However, if necessary, the vehicles shall be subjected to some of the tests described in paragraph 6. above, selected by the technical service conducting approval tests.

10. Penalties for non-conformity of production

- 10.1. The approval granted in respect of a vehicle type pursuant to this Regulation may be withdrawn if the requirement laid down in paragraph 9.1. above is not complied with or if its safety-belt anchorages or the ISOFIX anchorages system and ISOFIX top tether anchorage failed to pass the checks prescribed in paragraph 9. above.
- 10.2. If a Contracting Party to the Agreement which applies this Regulation withdraws an approval it has previously granted, it shall forthwith so notify the other Contracting Parties applying this Regulation, by means of a communication form conforming to the model in Annex 1 to this Regulation.

11. Operating instructions

The national authorities may require the manufacturers of vehicles registered by them to state clearly in the instructions for operating the vehicle

- 11.1. Where the anchorages are; and
- 11.2. For what types of belts the anchorages are intended (see Annex 1, item 5).

12. Production definitively discontinued

If the holder of the approval completely ceases to manufacture a type of safety-belt anchorages or a type of ISOFIX anchorages system and ISOFIX top tether anchorage approved in accordance with this Regulation, he shall so inform the authority which granted the approval. Upon receiving the relevant communication that authority shall inform thereof the other Contracting Parties to the 1958 Agreement, which apply this Regulation by means of a communication form conforming to the model in Annex 1 to this Regulation.

13. Names and addresses of Technical Services responsible for conducting approval tests and of Type Approval Authorities

The Contracting Parties to the 1958 Agreement applying this Regulation shall communicate to the United Nations secretariat the names and addresses of the Technical Services responsible for conducting approval tests and of the Type Approval Authorities which grant approval and to which forms certifying approval or extension, or refusal or extension or withdrawal of approval, issued in other countries, are to be sent.

14. Transitional provisions

- 14.1. As from the official date of entry into force of the 06 series of amendments, no Contracting Party applying this Regulation shall refuse to grant ECE approvals under this Regulation as amended by the 06 series of amendments.
- 14.2. As from 2 years after the enter into force of the 06 series of amendments to this Regulation, Contracting Parties applying this Regulation shall grant ECE type approvals only if the requirements of this Regulation, as amended by the 06 series of amendments, are satisfied.
- 14.3. As from 7 years after the enter into force of the 06 series of amendments to this Regulation, Contracting Parties applying this Regulation may refuse to recognize approvals which were not granted in accordance with the 06 series of amendments to this Regulation. However, existing approvals of the vehicle categories which are not affected by the 06 series of amendments to this Regulation shall remain valid and Contracting Parties applying this Regulation shall continue to accept them.
- 14.4. For vehicles not affected by paragraph 7.1.1. above, approvals granted according to the 04 series of amendments to this Regulation shall remain valid.
- 14.5. For vehicles not affected by Supplement 4 to the 05 series of amendments to this Regulation the existing approvals shall remain valid, if they had been granted in compliance with the 05 series of amendments, up to its Supplement 3.
- 14.6. As from the official date of entry into force of Supplement 5 to the 05 series of amendments, no Contracting Party applying this Regulation shall refuse to grant approvals under this Regulation as modified by Supplement 5 to the 05 series of amendments.

- 14.7. For vehicles not affected by Supplement 5 to the 05 series of amendments to this Regulation the existing approvals shall remain valid, if they had been granted in compliance with the 05 series of amendments, up to its Supplement 3.
- 14.8. As from 20 February 2005 for vehicles of category M₁, Contracting Parties applying this Regulation shall grant approvals only if the requirements of this Regulation, as amended by Supplement 5 to the 05 series of amendments, are satisfied.
- 14.9. As from 20 February 2007 for vehicles of category M₁, Contracting Parties applying this Regulation may refuse to recognize approvals which were not granted in accordance with Supplement 5 to the 05 series of amendments to this Regulation.
- 14.10. As from 16 July 2006 for vehicles of category N, Contracting Parties applying this Regulation shall grant approval only if the vehicle type satisfies the requirements of this Regulation as amended by the Supplement 5 to the 05 series of amendments.
- 14.11. As from 16 July 2008 for vehicles of category N, Contracting Parties applying this Regulation may refuse to recognize approvals not granted in accordance with Supplement 5 to the 05 series of amendments to this Regulation.
- 14.12. As from the official date of entry into force of the 07 series of amendments, no Contracting Party applying this Regulation shall refuse to grant approvals under this Regulation as amended by the 07 series of amendments.
- 14.13. As from 24 months after the date of entry into force of the 07 series of amendments, Contracting Parties applying this Regulation shall grant approvals only if the requirements of this Regulation, as amended by the 07 series of amendments, are satisfied.
- 14.14. As from 36 months after the date of entry into force of the 07 series of amendments, Contracting Parties applying this Regulation may refuse to recognize approvals which were not granted in accordance with the 07 series of amendments to this Regulation.
- 14.15. Notwithstanding paragraphs 14.13. and 14.14., approvals of the vehicle categories to the preceding series of amendments to the Regulation which are not affected by the 07 series of amendments shall remain valid and Contracting Parties applying the Regulation shall continue to accept them.
- 14.16. As long as there are no requirements concerning the compulsory fitting of safety-belt anchorages for folding seats in their national requirements at the time of acceding to this Regulation, Contracting Parties may continue to allow this non-fitment for the purpose of national approval and in this case these bus categories cannot be type approved under this Regulation.
- 14.17. As from the official date of entry into force of Supplement 2 to the 07 series of amendments, no Contracting Party applying this Regulation shall refuse to grant type approval under this Regulation as amended by Supplement 2 to the 07 series of amendments.

- 14.18. As from 12 months after the official date of entry into force of Supplement 2 to the 07 series of amendments, Contracting Parties applying this Regulation shall grant type approvals only to those types of vehicle which comply with the requirements of this Regulation as amended by Supplement 2 to the 07 series of amendments.
- 14.19. Contracting Parties applying this Regulation shall not refuse to grant extensions of approvals, even if Supplement 2 to the 07 series of amendments is not fulfilled.

Annex 1

Communication

(Maximum format: A4 (210 x 297 mm))



issued by: Name of Administration:

.....
.....
.....

concerning²: Approval granted
 Approval extended
 Approval refused
 Approval withdrawn
 Production definitively discontinued

of a vehicle type with regard to safety-belt anchorages and ISOFIX anchorages systems,
and ISOFIX top tether anchorages and i-Size seating positions if any pursuant to
Regulation No. 14

Approval No..... Extension No.....

1. Trade name or mark of the power-driven vehicle
 2. Type of vehicle
 3. Manufacturer's name and address
 4. If applicable, name and address of manufacturer's representative
-

¹ Distinguishing number of the country which has granted/extended/refused/withdrawn approval (see approval provisions in the Regulation).

² Strike out what does not apply.

5. Designation of the type of belts and retractors authorized for fitting to the anchorages with which the vehicle is equipped:

| | | Anchorage on* | |
|-------|-----------------|-------------------|----------------|
| | | vehicle structure | seat structure |
| Front | Right-hand seat | lower anchorages | { outboard |
| | | upper anchorage | { inboard |
| | Middle seat | lower anchorages | { right |
| | | upper anchorage | { left |
| | Left-hand seat | lower anchorages | { outboard |
| | | upper anchorage | { inboard |
| Rear | Right-hand seat | lower anchorages | { outboard |
| | | upper anchorage | { inboard |
| | Middle seat | lower anchorages | { right |
| | | upper anchorage | { left |
| | Left-hand seat | lower anchorages | { outboard |
| | | upper anchorage | { inboard |

* Insert in the actual position the following letter(s):

- "A" for a three-point belt,
- "B" for lap belts,
- "S" for special-type belts; in this case the type shall be stated under "Remarks",
- "Ar", "Br" or "Sr" for belts with retractors,
- "Ae", "Be" or "Se" for belts with an energy absorption device,
- "Are", "Bre" or "Sre" for belts with retractors and energy-absorption devices on at least one anchorage.

Remarks:

6. Description of seats³.....

7. Utilises ISOFIX exemption permitted by paragraph 5.3.8.8. of this Regulation: Yes/No²"

8. Description of the adjustment, displacement and locking systems either of the seat or of its parts³:

9. Description of seat anchorage³:.....

³ Only if the anchorage is affixed on the seat or if the seat supports the belt strap.

10. Description of particular type of safety-belt required in the case of an anchorage located in the seat structure or incorporating an energy-dissipating device:
11. Vehicle submitted for approval on:
12. Technical Service responsible for conducting approval tests:
13. Date of report issued by that Service:
14. Number of report issued by that Service:
15. Approval granted/extended/refused/withdrawn²
16. Position of approval mark on vehicle:
17. Place:
18. Date:
19. Signature:

20. The following documents, filed with the administration service which has granted approval and available on request are annexed to this communication:

Drawings, diagrams and plans of the belt anchorages, ISOFIX anchorages systems, of the top tether anchorages if any, and of the vehicle structure;

Photographs of the belt anchorages, of the ISOFIX anchorages systems, of the top tether if any, and of the vehicle structure;

drawings, diagrams and plans of the belt anchorages, ISOFIX anchorages systems, of the top tether anchorages if any, vehicle floor contact surface of i-Size seating positions if any, and of the vehicle structure;

photographs of the belt anchorages, of the ISOFIX anchorages systems, of the top tether if any, vehicle floor contact surface of i-Size seating positions if any, and of the vehicle structure;

Annex 2

Arrangements of the approval mark

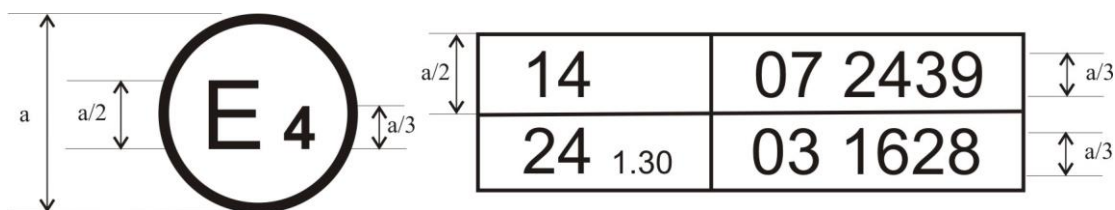
Model A
(see paragraph 4.4. of this Regulation)



$a = 8 \text{ mm min.}$

The above approval mark affixed to a vehicle shows that the vehicle type concerned has, with regard to safety-belt anchorages, been approved in the Netherlands (E 4), pursuant to Regulation No. 14, under the number 072439. The first two digits of the approval number indicate that Regulation No. 14 already included the 07 series of amendments when the approval was given.

Model B
(see paragraph 4.5. of this Regulation)



$a = 8 \text{ mm min.}$

The above approval mark affixed to a vehicle shows that the vehicle type concerned has been approved in the Netherlands (E 4) pursuant to Regulations Nos. 14 and 24*. (In the case of the latter Regulation the corrected absorption co-efficient is 1.30 m^{-1}). The approval numbers indicate that on the dates on which these approvals were granted, Regulation No. 14 included the 07 series of amendments and Regulation No. 24 was in its 03 series of amendments.

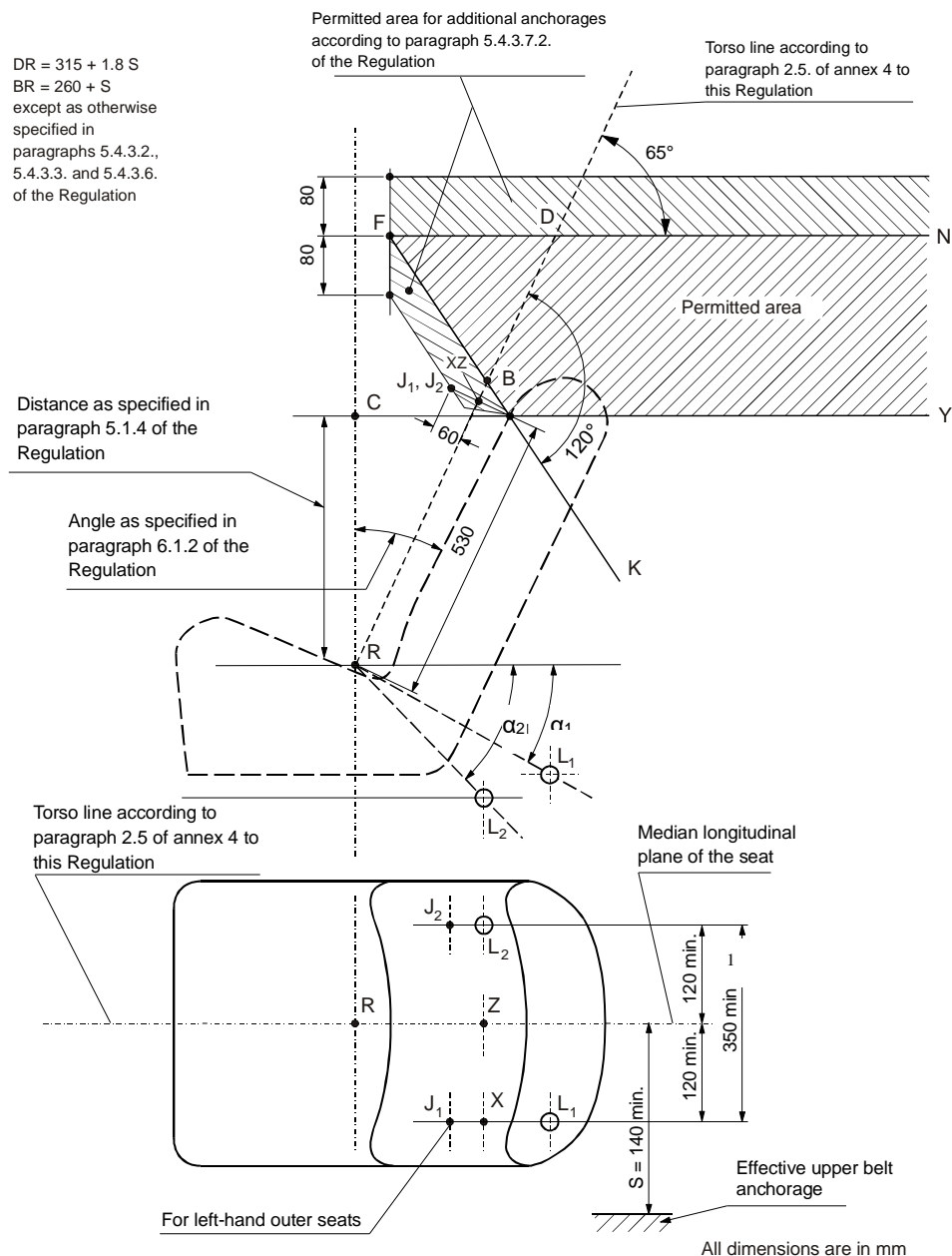
* The second number is given merely as an example.

Annex 3

Location of effective belt anchorages

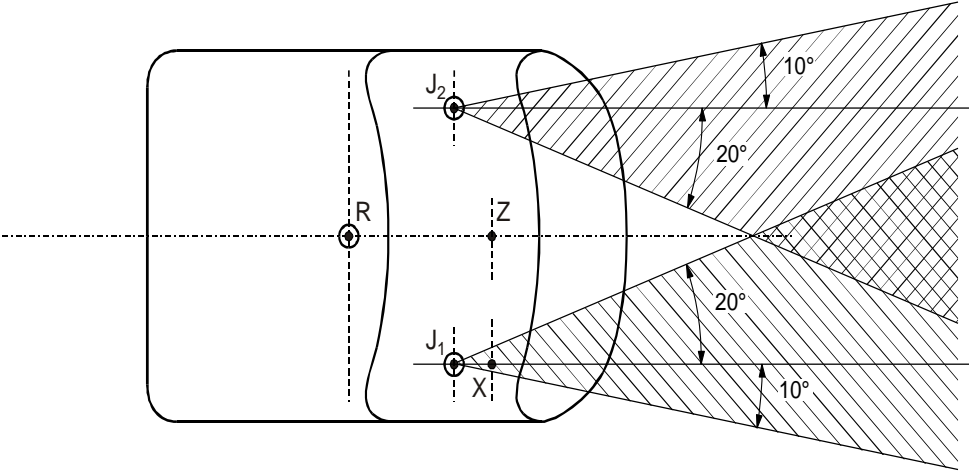
Figure 1
 Areas of location of effective belt anchorages

(The drawing shows one example, where the upper anchorage is fixed to the vehicle body side panel)



¹ 240 mm minimum for the central rear seating positions of M₁ and N₁ categories of vehicles

Figure 2
Effective upper anchorages conforming to paragraph 5.4.3.7.3. of the Regulation



Annex 4

Procedure for determining the "H" point and the actual torso angle for seating positions in motor vehicles¹

Appendix 1 - Description of the three dimensional "H" point machine¹

Appendix 2 - Three-dimensional reference system¹

Appendix 3 - Reference data concerning seating positions¹

¹ The procedure is described in Annex 1 to the Consolidated Resolution on the Construction of Vehicles (R.E.3) (document ECE/TRANS/WP.29/78/Rev.2 - www.unece.org/trans/main/wp29/wp29wgs/wp29gen/wp29resolutions.html)

Annex 5

Traction device

Figure 1

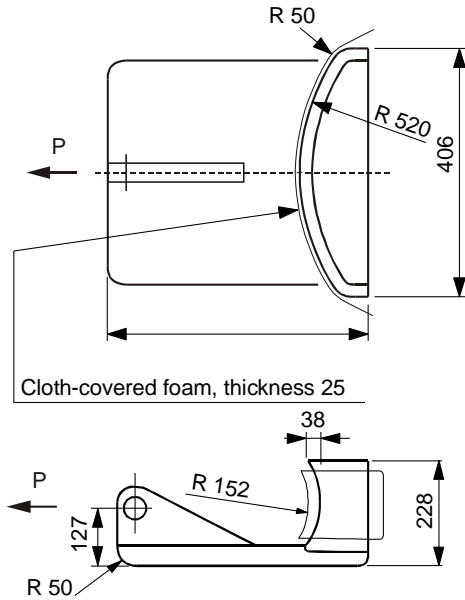
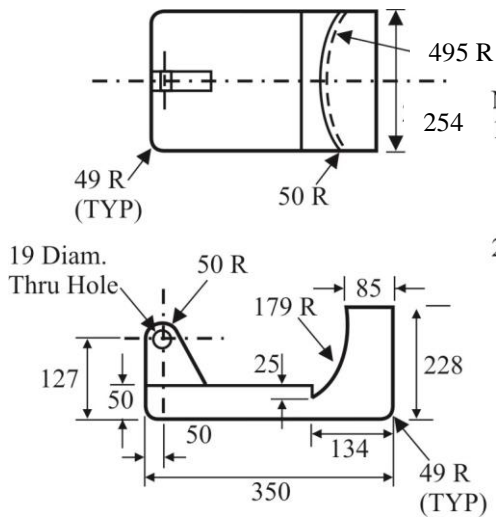


Figure 1a



NOTES:
 1. Block Covered by 25 Med.
 Density Canvas Covered
 Foam Rubber

2. All dimensions in
 millimetres (mm)



Figure 1b

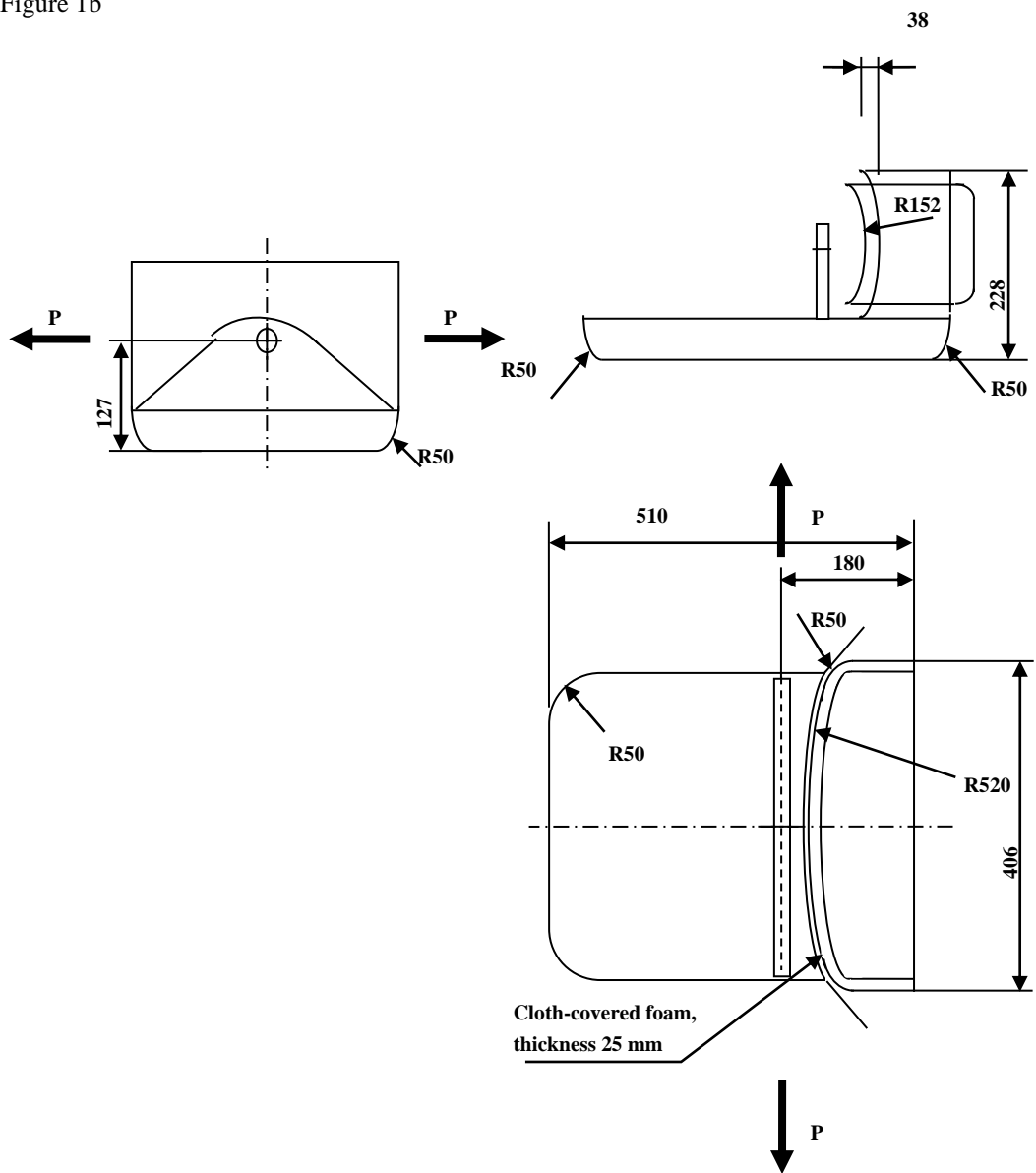
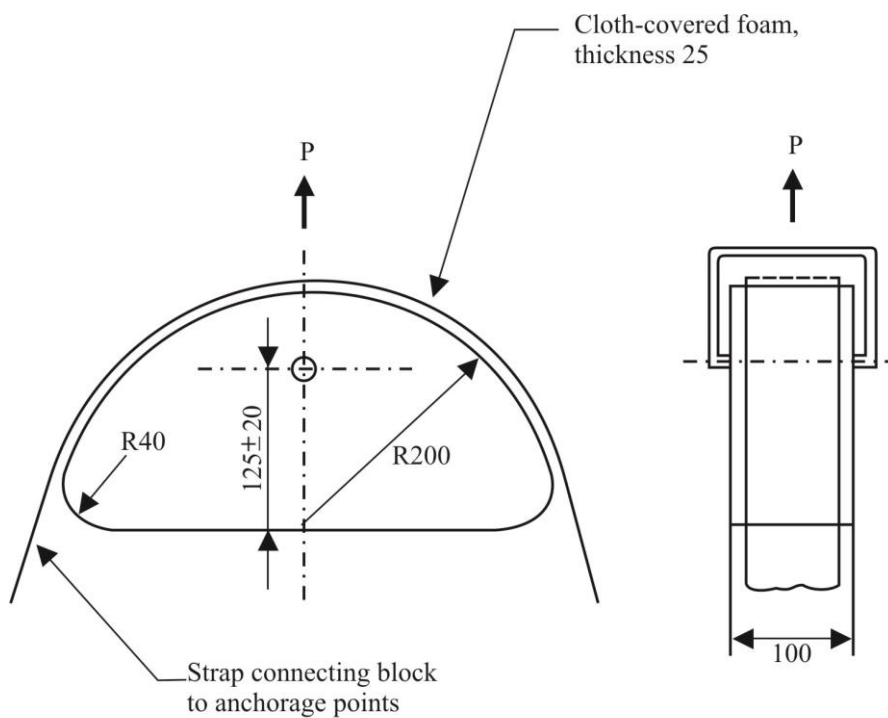


Figure 2

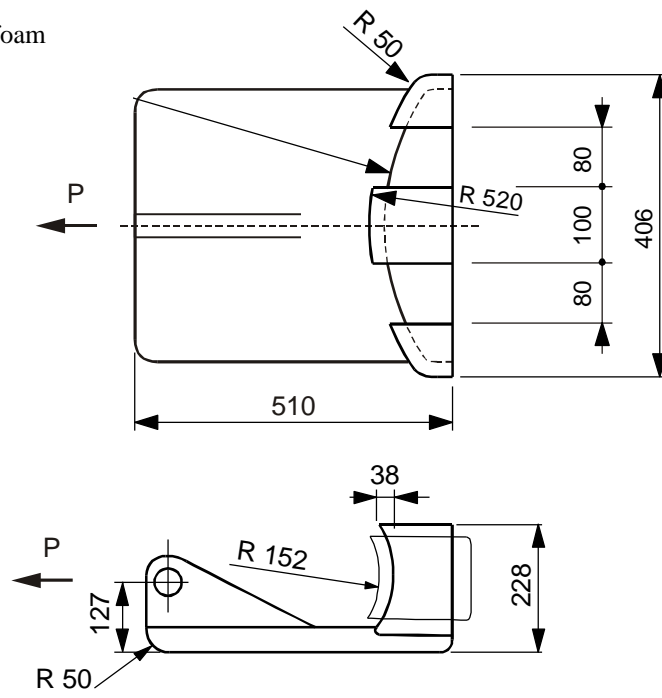


All dimensions are in millimetres

For the fixing of the strap the shoulder belt traction device may be modified by adding of two land edges and/or some bolts to avoid any drop off of the strap during the pull test.

Figure 3

Cloth-covered foam
thickness 25



All dimensions are in mm

Annex 6

Minimum number of anchorage points and location of lower anchorages

| Vehicle category | Forward facing seating positions | | | | Rearward facing | Side facing |
|---------------------------------|----------------------------------|----------|----------|----------|-----------------|-------------|
| | Outboard | | Centre | | | |
| | Front | Other | Front | Other | | |
| M ₁ | 3 | 3 | 3 | 3 | 2 | - |
| M ₂ ≤ 3.5 tonnes | 3 | 3 | 3 | 3 | 2 | - |
| M ₂ > 3.5 tonnes | 3 ⊕ | 3 or 2 † | 3 or 2 † | 3 or 2 † | 2 | - |
| M ₃ | 3 ⊕ | 3 or 2 † | 3 or 2 † | 3 or 2 † | 2 | 2 |
| N ₁ | 3 | 3 or 2 ∅ | 3 or 2 * | 2 | 2 | - |
| N ₂ & N ₃ | 3 | 2 | 3 or 2 * | 2 | 2 | - |

Key to symbols:

- 2: Two lower anchorages, which allow the installation of a safety-belt type B, or of safety-belts types Br, Br3, Br4m or Br4Nm, where required by the Consolidated Resolution on the Construction of Vehicles (R.E.3), Annex 13, Appendix 1.
- 3: Two lower anchorages and one upper anchorage which allow the installation of a three-point safety-belt type A, or of safety-belts types Ar, Ar4m or Ar4Nm, where required by the Consolidated Resolution on the Construction of Vehicles (R.E.3), Annex 13, Appendix 1.
- ∅: Refers to paragraph 5.3.3. (Two anchorages permitted if a seat is inboard of a passageway)
- *: Refers to paragraph 5.3.4. (Two anchorages permitted if the windscreen is outside reference zone)
- †: Refers to paragraph 5.3.5. (Two anchorages permitted if nothing is in the reference zone)
- ⊕: Refers to paragraph 5.3.7. (Special provision for the upper deck of a vehicle)

Annex 6 - Appendix 1

Location of lower anchorages - Angle requirements only

| Seat | | M_1 | Other than M_1 |
|-------------|--|--|------------------|
| Front* | buckle side (α_2) | 45° - 80° | 30° - 80° |
| | other than buckle side (α_1) | 30° - 80° | 30° - 80° |
| | angle constant | 50° - 70° | 50° - 70° |
| | bench - buckle side (α_2) | 45° - 80° | 20° - 80° |
| | bench - other than buckle side (α_1) | 30° - 80° | 20° - 80° |
| | adjustable seat with seat back angle < 20° | 45° - 80° (α_2)* 20° - 80° (α_1)* | 20° - 80° |
| Rear \neq | | 30° - 80° | 20° - 80° Ψ |
| Folding | No belt anchorage required. If anchorage fitted: see angle requirements Front and Rear. | | |

Notes:

\neq : outboard and centre.

*: if angle is not constant see paragraph 5.4.2.1.

Ψ : 45° - 90° in the case of seats on M_2 and M_3 vehicles.

Annex 7

Dynamic test as an alternative to the safety-belt anchorages static strength test

1. Scope

This annex describes a dynamic sled test that can be performed as an alternative to the safety-belt anchorages static strength test prescribed in paragraphs 6.3. and 6.4. of this Regulation.

This alternative can apply at the request of the car manufacturer in the case of a group of seats where all the seating positions are equipped with 3-point safety-belts to which thorax load limiter functions are associated and when the group of seats additionally comprises a seating position for which the upper safety-belt anchorage is located on the seat structure.
2. Prescriptions
 - 2.1. In the dynamic test prescribed in paragraph 3. of this annex, there shall be no rupture of any anchorage or surrounding area. A programmed rupture necessary for the functioning of the load limiter device is however permitted.

The minimum spacings for the effective lower anchorages specified in paragraph 5.4.2.5. of this Regulation, and the requirements for the effective upper anchorages specified in paragraph 5.4.3.6. of this Regulation and, when applicable, completed by the following paragraph 2.1.1., shall be respected.
 - 2.1.1. For vehicles of category M₁ of a total permissible mass not exceeding 2.5 tonnes, the upper safety-belt anchorage, if attached to the seat structure, shall not be displaced forward of a transverse plane passing through the R point and point C of the seat in question (see Figure 1 of Annex 3 to this Regulation).

For vehicles other than mentioned above, the upper safety-belt anchorage shall not be displaced forward of a transverse plane inclined 10° in forward direction and passing through the R point of the seat.
 - 2.2. In vehicles where such devices are used, the displacement and locking devices enabling the occupants of all seats to leave the vehicle must still be operable by hand after the test.
 - 2.3. The vehicle owner's manual shall include indications that each safety-belt shall only be replaced by an approved safety-belt for the considered seating position in the vehicle, and shall in particular identify those seating positions which may only be fitted with an appropriate safety-belt equipped with a load limiter.
3. Dynamic test conditions
 - 3.1. General conditions

The general conditions described in paragraph 6.1. of this Regulation apply to the test described in this annex.

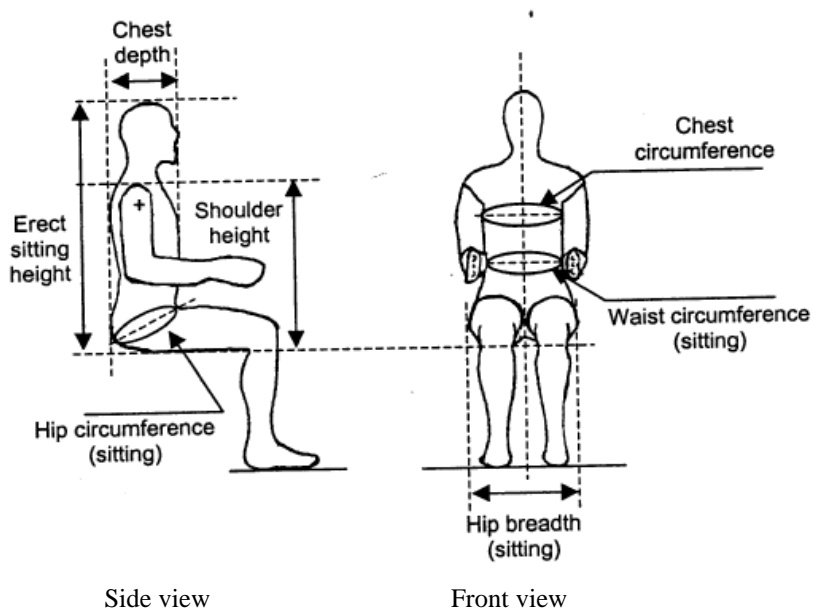
- 3.2. Installation and preparation
- 3.2.1. Sled
- The sled must be so constructed that no permanent deformation appears after the test. It must be so guided that, during the impact phase, the deviation does not exceed 5° in the vertical plane and 2° in the horizontal plane.
- 3.2.2. Securing of the vehicle structure
- The part of the vehicle structure considered essential for the vehicle rigidity regarding the seat anchorages and the safety-belt anchorages shall be secured on the sled, according to the disposals described in paragraph 6.2. of this Regulation.
- 3.2.3. Restraint systems
- 3.2.3.1. The restraint systems (the complete seats, the safety-belt assemblies and the load limiter devices) shall be mounted on the vehicle structure according to the series production vehicle specifications.
- The vehicle environment facing the tested seat (dashboard, seat, etc., depending on the tested seat) can be mounted on the test sled. If there were a frontal airbag, it has to be deactivated.
- 3.2.3.2. At the request of the car manufacturer and in agreement with the technical service in charge of the tests, some components of the restraint systems other than the complete seats, the safety-belt assemblies and the load limiter devices, may not be mounted on the test sled or may be replaced by components having equivalent or lower stiffness and whose dimensions are comprised in the vehicle interior fittings dimensions, provided that the tested configuration is at least as unfavourable as the series configuration regarding the forces applying to the seat and safety-belt anchorages.
- 3.2.3.3. The seats shall be adjusted as required in paragraph 6.1.2. of this Regulation, in the position for use chosen by the technical service in charge of the tests as the one giving the most adverse conditions regarding the anchorages strength and compatible with the installation of the dummies in the vehicle.
- 3.2.4. Dummies
- A dummy whose dimensions and mass are defined in Annex 8 shall be positioned on each seat and restrained by the safety-belt provided in the vehicle.
- No dummy instrumentation is required.
- 3.3. Test
- 3.3.1. The sled shall be so propelled that, during the test, its speed variation is 50 km/h. The sled deceleration shall be within the corridor specified in Annex 8 of Regulation No. 16.
- 3.3.2. If applicable, the activation of additional restraining devices (preloading devices, etc., except airbags) is triggered according to the car manufacturer's indications.
- 3.3.3. It shall be checked that the safety-belt anchorages' displacement does not exceed the limits specified in paragraphs 2.1. and 2.1.1. of this annex.

Annex 8

Dummy specifications*

| | |
|------------------------------------|-------------|
| Mass | 97.5 ± 5 kg |
| Erect sitting height | 965 mm |
| Hip breadth (sitting) | 415 mm |
| Hip circumference (sitting) | 1200 mm |
| Waist circumference (sitting) | 1080 mm |
| Chest depth | 265 mm |
| Chest circumference | 1130 mm |
| Shoulder height | 680 mm |
| Tolerance on all length dimensions | ±5 per cent |

Remark: A sketch explaining the dimensions is given in the Figure below.



* Devices described in the Australian Design Rule (ADR) 4/03 and Federal Motor Vehicle Safety Standard (FMVSS) No. 208 are considered equivalent.

Annex 9

ISOFIX anchorages systems and ISOFIX top tether anchorages

Figure 1
Static force application device (SFAD), isometric views

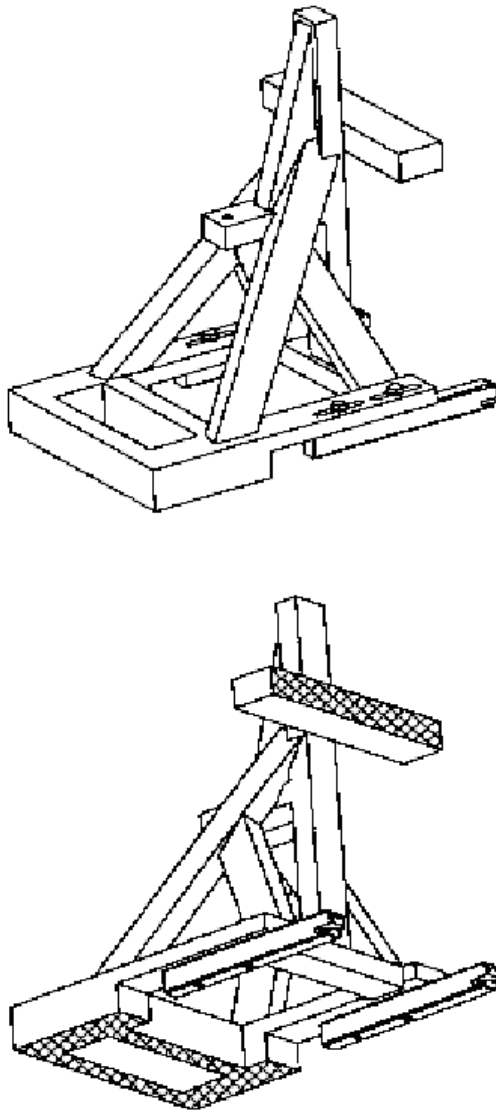
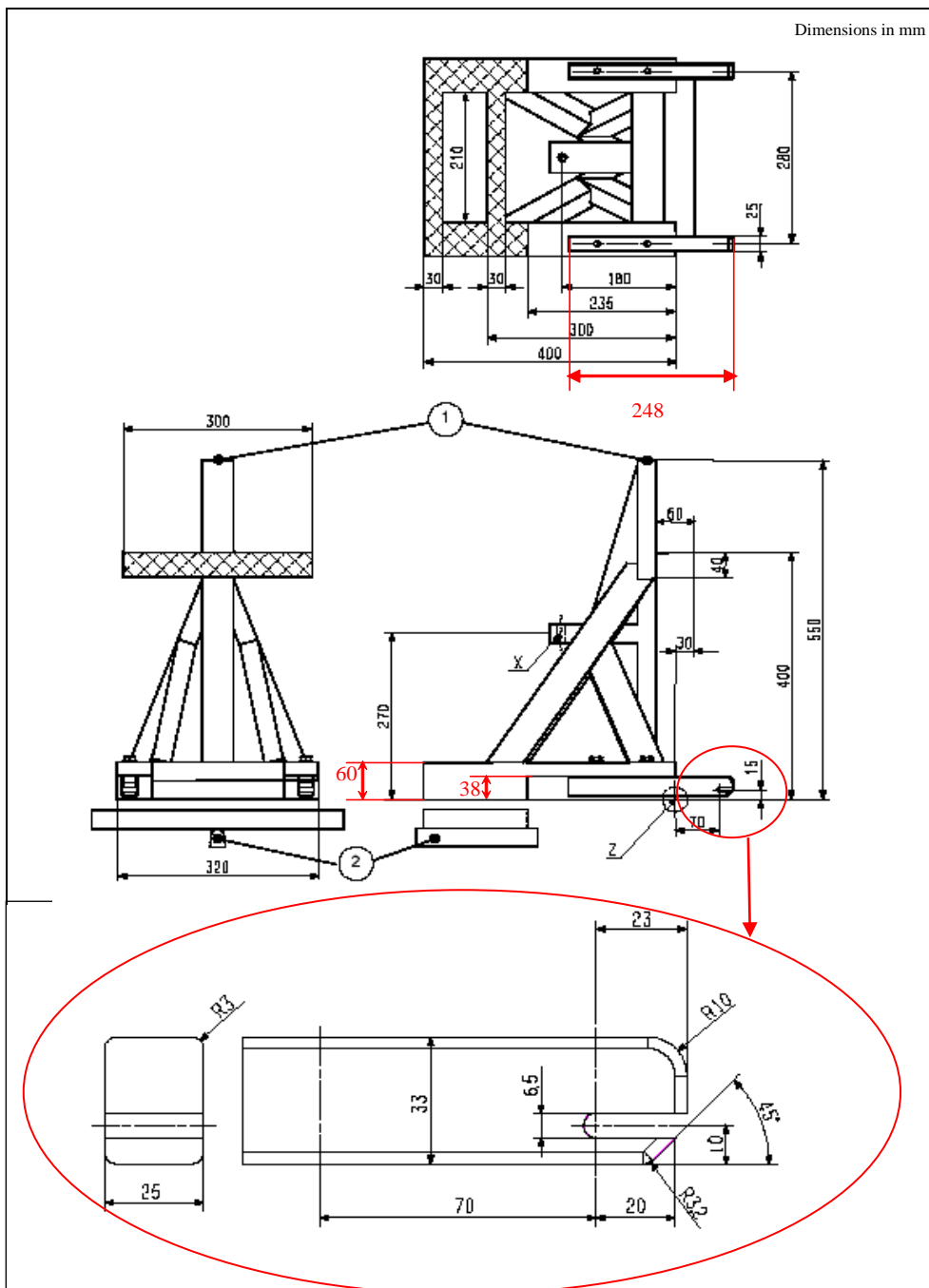


Figure 2
 Static force application device (SFAD), dimensions



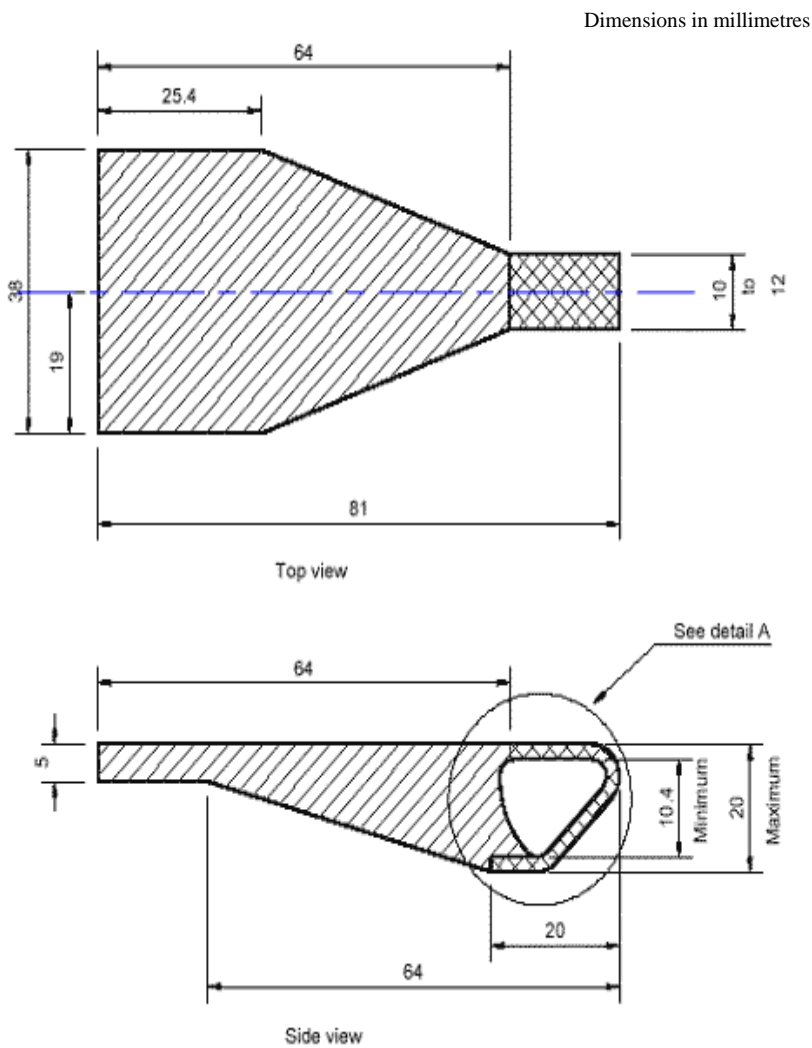
Key

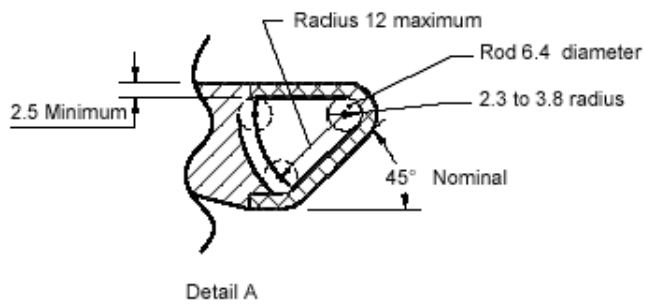
- 1 Top tether attachment point

2 Pivot attachment for stiffness testing as described below.

Stiffness of SFAD: When attached to rigid anchorage bar(s) with the front cross member of the SFAD supported by a rigid bar that is held at the centre by a longitudinal pivot 25 mm below the SFAD base (to allow bending and twisting of the SFAD base) the movement of point X shall not be greater than 2 mm in any direction when forces are applied in accordance with Table 1 of paragraph 6.6.4. of this Regulation. Any deformation of the ISOFIX anchorages system shall be excluded from the measurements.

Figure 3
ISOFIX Top tether connector (hook type) dimensions





LEGEND:

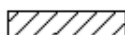

-  Surrounding structure (if present)
-  Area in which the tether strap hook interface profile must be wholly located.

Figure 4
Distance between both low anchorage zones

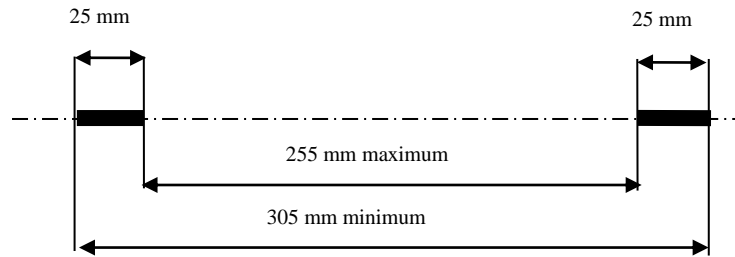
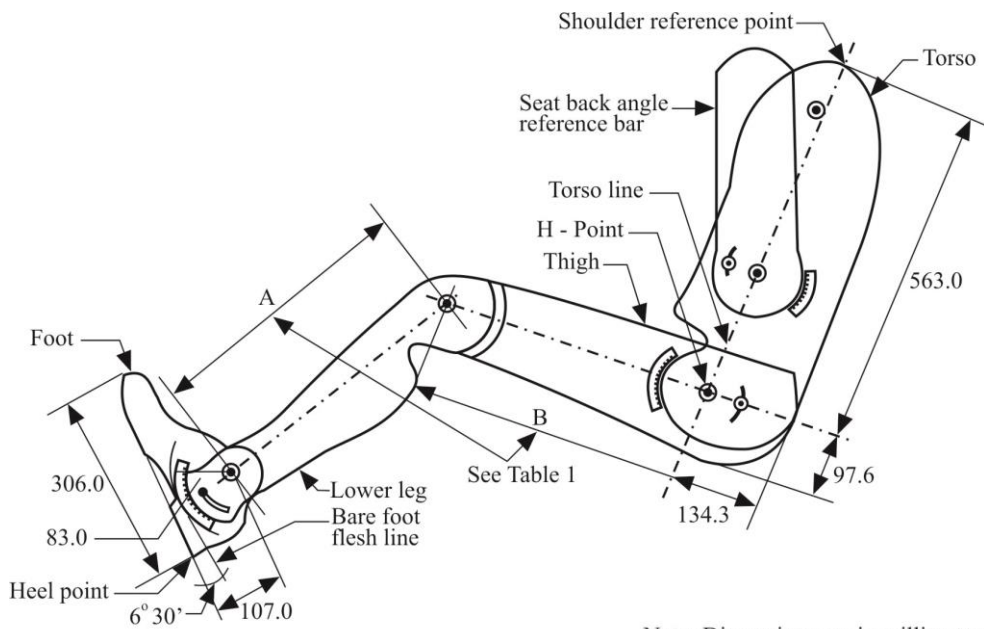
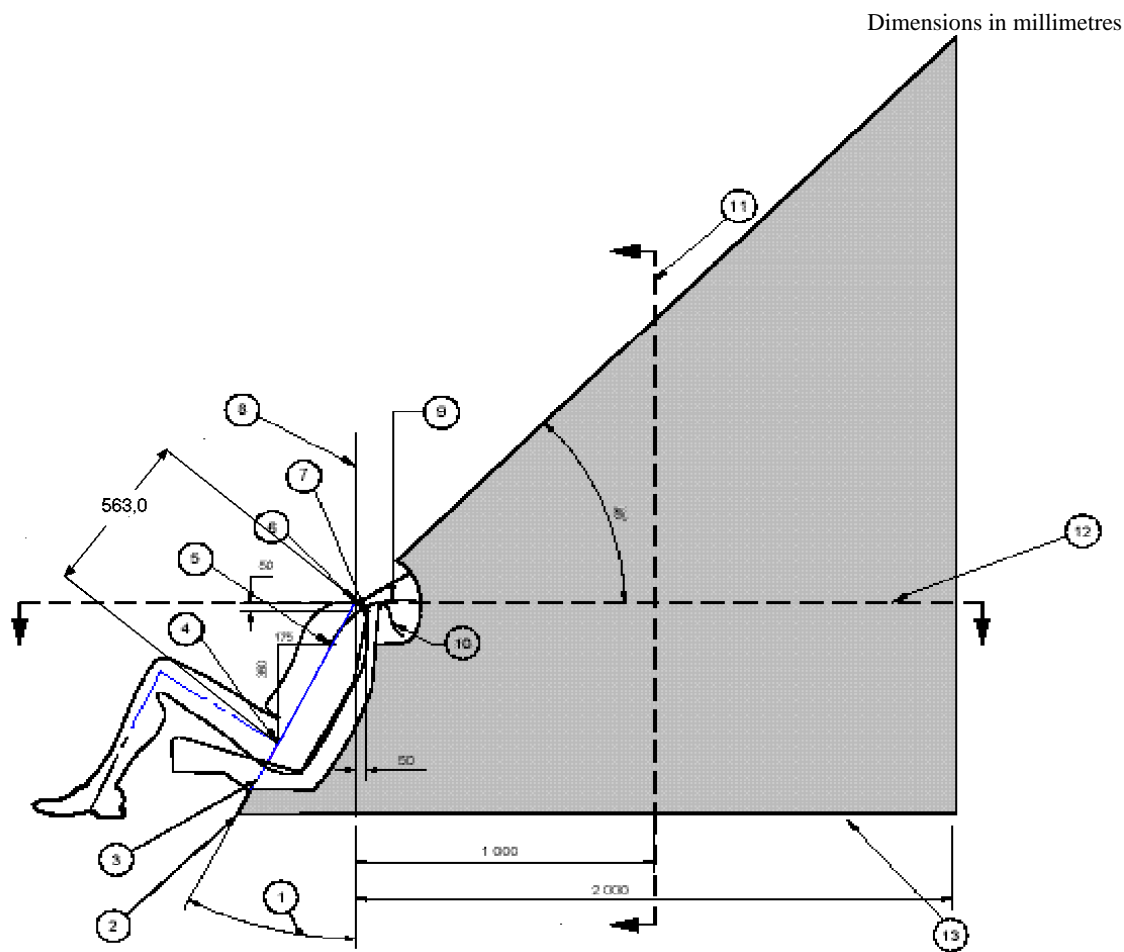


Figure 5
Two dimensions template



Note: Dimensions are in millimetres

Figure 6
 ISOFIX Top tether anchorage location, ISOFIX zone - Side view



Key

- 1 Back angle
- 2 Intersection of torso line reference plane and floor pan
- 3 Torso line reference plane
- 4 H-Point
- 5 "V" point
- 6 "R" point
- 7 "W" point
- 8 Vertical longitudinal plane
- 9 Strap wrap-around length from "V" point: 250 mm
- 10 Strap wrap-around length from "W" point: 200 mm
- 11 "M" plane cross-section
- 12 "R" plane cross-section
- 13 Line represents the vehicle specific floor pan surface within the prescribed zone

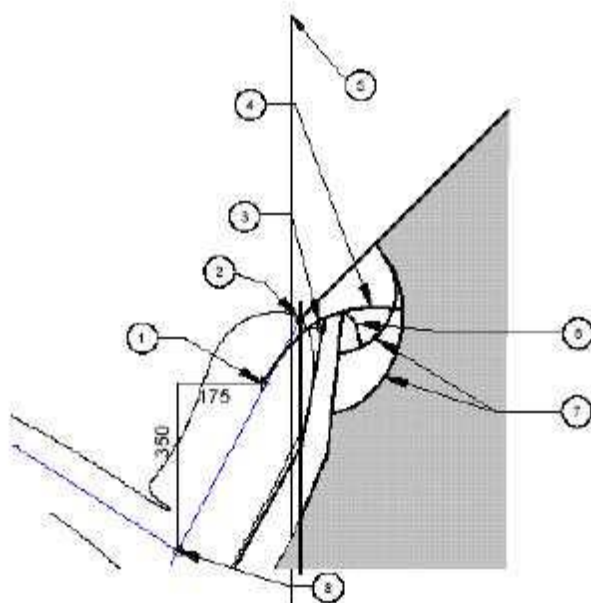
Notes:

- 1 Portion of top tether anchorage that is designed to bind with the top tether hook to be located within shaded zone
- 2 "R" Point: Shoulder reference point
- 3 "V" Point: V-reference point, 350 mm vertically above and 175 mm horizontally back from H-point
- 4 "W" Point W-reference point, 50 mm vertically below and 50 mm horizontally back from "R" point
- 5 "M" Plane: M-reference plane, 1,000 mm horizontally back from "R" point
- 6 The forward most surfaces of the zone are generated by sweeping the two wraparound lines throughout their extended range in the front part of the zone. The wraparound lines represent the minimum adjusted length of typical top tether straps extending from either the top of the CRS (W-point), or lower on the back of the CRS (V-Point).

Figure 7

ISOFIX Top tether anchorage location, ISOFIX zone - Enlarged side view of wrap-around area

Dimensions in millimetres



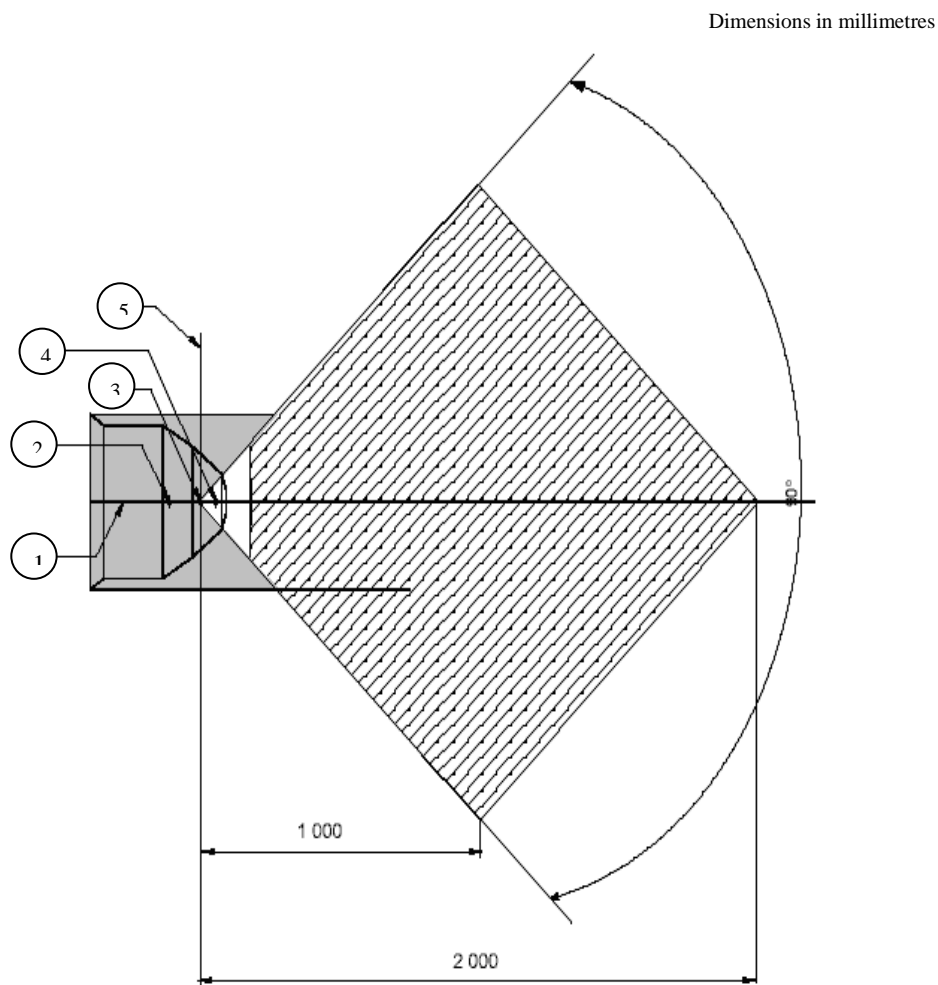
Key

- 1 "V" point
- 2 "R" point
- 3 "W" point
- 4 Strap wrap-around length from "V" point: 250 mm
- 5 Vertical longitudinal plane
- 6 Strap wrap-around length from "W" point: 200 mm
- 7 Arcs created by wrap-around lengths
- 8 H-point

Notes:

- 1 Portion of top tether anchorage that is designed to bind with the top tether hook to be located within shaded zone
- 2 "R" point: Shoulder reference point
- 3 "V" point: V-reference point, 350 mm vertically above and 175 mm horizontally back from H-point
- 4 "W" point: W-reference point, 50 mm vertically below and 50 mm horizontally back from "R" point
- 5 "M" plane: M-reference plane, 1,000 mm horizontally back from "R" point
- 6 The forward most surface of the zone are generated by sweeping the two wraparound lines throughout their extended range in the front part of the zone. The wraparound lines represent the minimum adjusted length of typical top tether straps extending from either the top of the CRS (W-point), or lower on the back of the CRS (V.point).

Figure 8
SOFIX Top tether anchorage location, ISOFIX zone - Plan view
 (R-plane cross section)



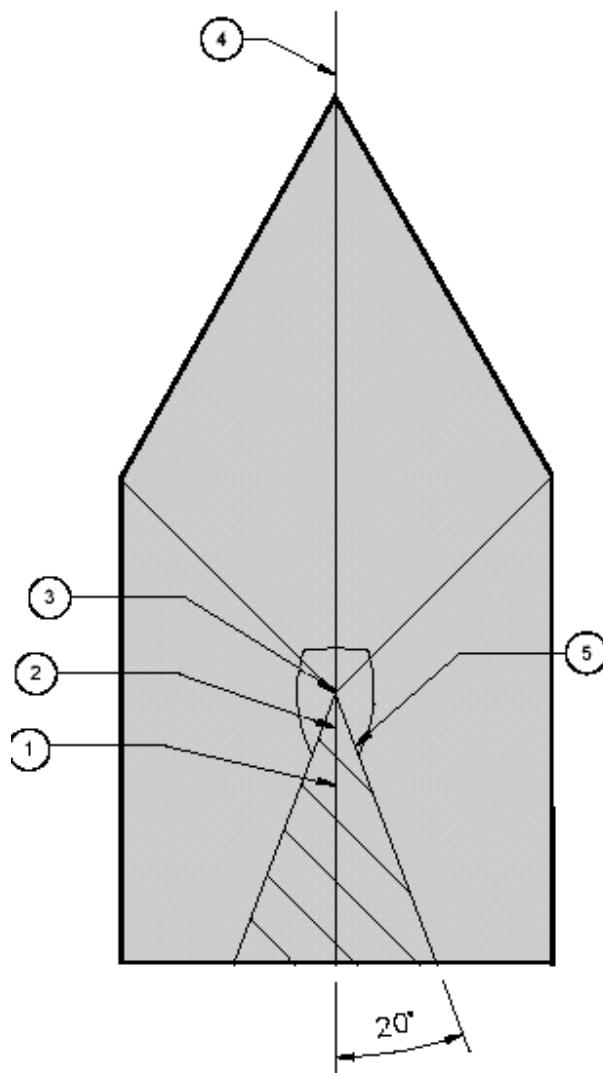
Key

- 1 Median plane
- 2 "V" point
- 3 "R" point
- 4 "W" point
- 5 Vertical longitudinal plane

Notes:

- 1 Portion of top tether anchorage that is designed to bind with the top tether hook to be located within shaded zone
- 2 "R" point: Shoulder reference point
- 3 "V" point: V-reference point, 350 mm vertically above and 175 mm horizontally back from H-point
- 4 "W" point: W-reference point, 50 mm vertically below and 50 mm horizontally back from "R" point

Figure 9
ISOFIX Top tether anchorage location, ISOFIX zone - Front view



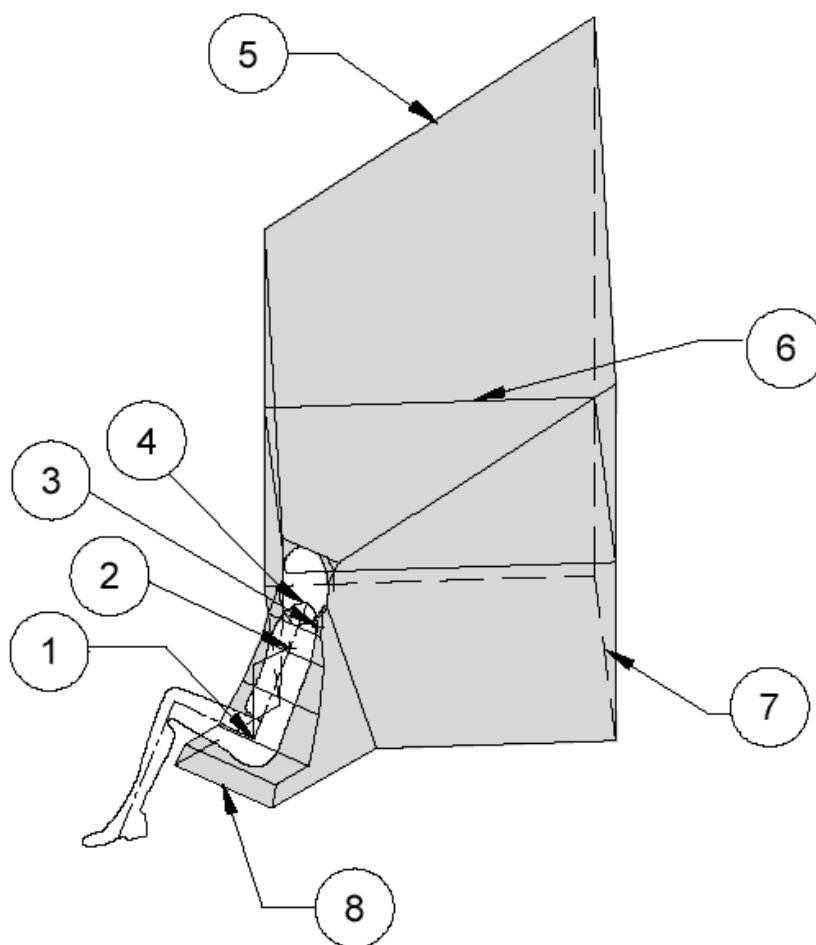
Key

- 1 "V" point
- 2 "W" point
- 3 "R" point
- 4 Median plane
- 5 Area view along torso reference plane

Notes:

- 1 Portion of top tether anchorage that is designed to bind with the top tether hook to be located within shaded zone
- 2 "R" point: Shoulder reference point
- 3 "V" point: V-reference point, 350 mm vertically above and 175 mm horizontally back from H-point
- 4 "W" point: W-reference point, 50 mm vertically below and 50 mm horizontally back from "R" point

Figure 10
ISOFIX Top tether anchorage location, ISOFIX zone -
Three-dimensional schematic view



Key

- 1 "H" point
- 2 "V" point
- 3 "W" point
- 4 "R" point
- 5 45° plane
- 6 "R" plane cross-section
- 7 Floor pan surface
- 8 Front edge of zone

Notes:

- 1 Portion of top tether anchorage that is designed to bind with the top tether hook to be located within shaded zone
- 2 "R" point: Shoulder reference point

Figure 11
Alternative method of locating the top tether anchorage using the "ISO/F2" (B) fixture, ISOFIX zone - side, top and rear views

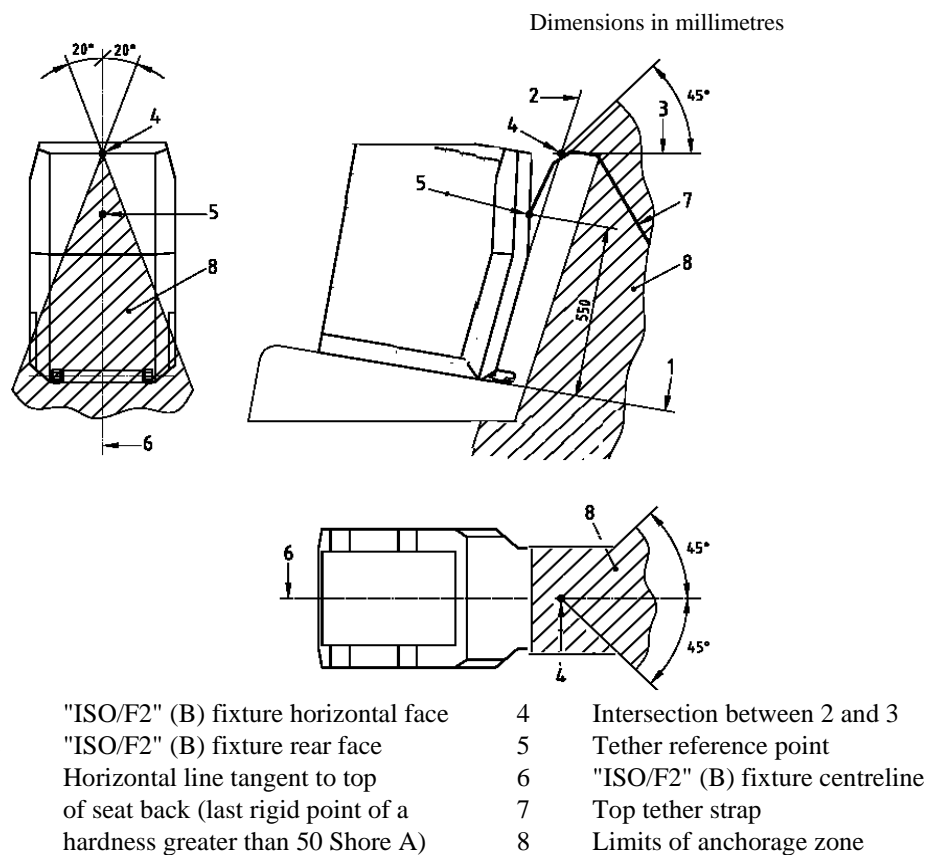


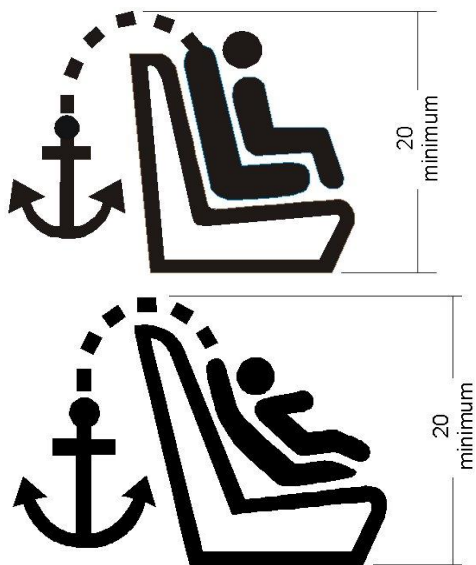
Figure 12
ISOFIX low anchorage symbol



Notes:

- 1 Drawing not to scale.
- 2 Symbol may be shown in mirror image.
- 3 Colour of the symbol at choice of manufacturer.

Figure 13
Symbol used to identify the location of a top tether anchorage that is under a cover



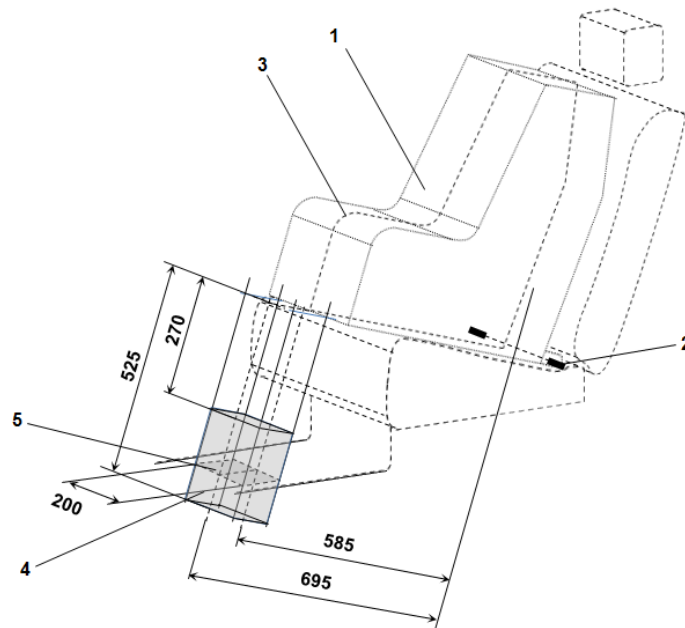
Notes:

- 1 Dimensions in mm
- 2 Drawing not to scale
- 3 The symbol shall be clearly visible either by means of contrast colours or by adequate relief if it is moulded or embossed.

"Annex 10

i-Size seating position

Figure 1
3D view of the support leg foot assessment volume

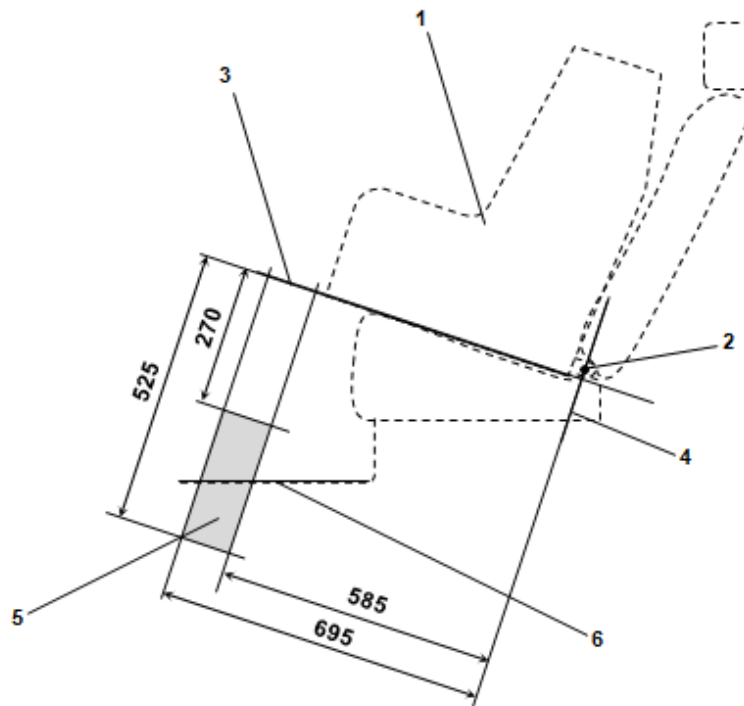


Key:

1. Child Restraint Fixture (CRF).
2. ISOFIX low anchorages bar.
3. Median longitudinal plane of the CRF.
4. Support leg foot assessment volume.
5. Vehicle floor contact surface.

Note: Drawing not to scale.

Figure 2
Side view of the support leg foot assessment volume

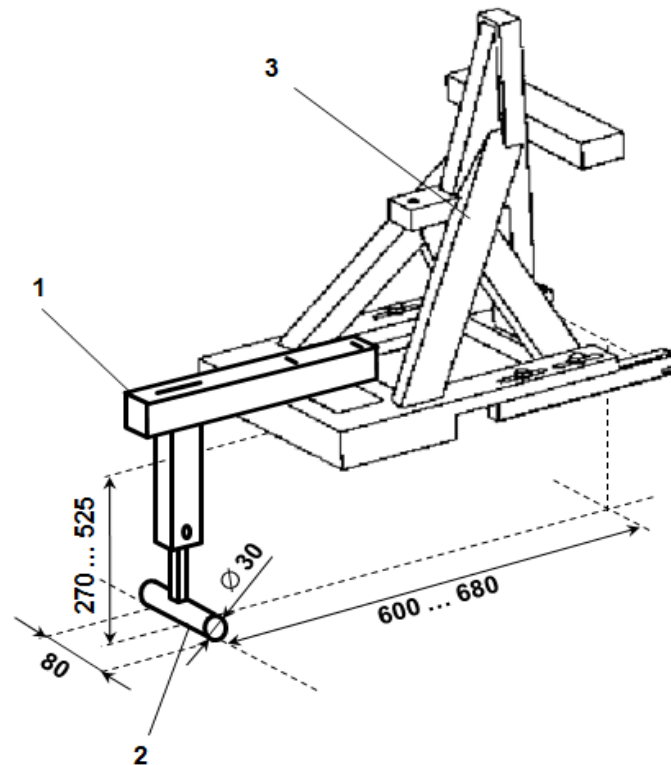


Key:

1. Child Restraint Fixture (CRF).
2. ISOFIX low anchorages bar.
3. Plane formed by the bottom surface of the CRF when installed in the designated seating position.
4. Plane passing through the lower anchorage bar and oriented perpendicular to the median longitudinal plane of the CRF and perpendicular to the plane formed by the bottom surface of the CRF when installed in the designated seating position.
5. Support leg foot assessment volume within which the vehicle floor has to be located. This volume represents the length and height adjustment range of an i-Size child restraint system support leg.
6. Vehicle floor.

Note: Drawing not to scale.

Figure 3
Example for a modified Static force application device with support leg test probe (SFAD_{SL}) showing the required adjustment range and dimensions of the support leg foot



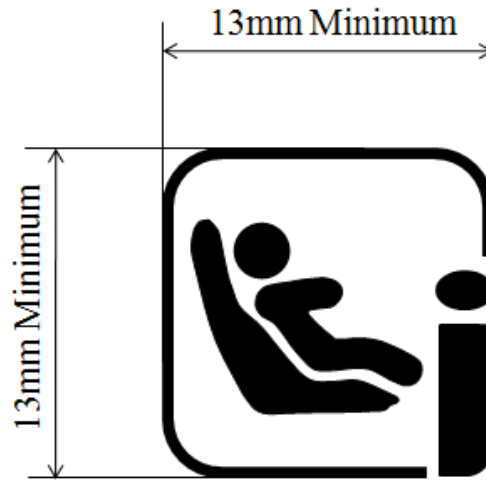
Key:

1. Support leg test device.
2. Support leg foot.
3. SFAD (as defined in annex 9 of this Regulation).

Notes:

1. Drawing not to scale.
2. The support leg test device shall:
 - (a) Ensure testing within the entire vehicle floor contact surface defined for individual i-Size seating positions;
 - (b) Be rigidly fixed to the SFAD so that the forces applied to the SFAD will directly induce test forces into the vehicle floor, without reduction of the reactive test forces due to damping within or deformation of the support leg test device itself.
3. The support leg foot shall consist of a cylinder, having a width of 80 mm, a diameter of 30 mm and on both side faces rounded edges with a 2.5mm radius.
4. In case of incremental height adjustment, the distance between the steps for adjustment shall not be more than 20 mm.

Figure 4
Symbol used to identify an i-Size seating position



Notes:

1. Drawing not to scale.
2. Colour of the symbol is the manufacturer's choice.